

1. 7:00 P.M. Agenda

Documents:

[1. 06-02-2025 AGENDA 5.30.2025.PDF](#)

1.1. 7:00 PM 06-02-2025 Agenda And Meeting Materials

Documents:

[UPDATED 2025-06-02 SELECTBOARD MEETING MATERIALS.PDF](#)

TOWN *of* HANOVER

**NOTICE OF PUBLIC MEETING
SELECTBOARD
Monday, June 2, 2025, at 7:00 PM
Board Room, Municipal Building
41 South Main Street, Hanover, NH**

AGENDA

- 1. Opening of Meeting – 1 Minute**
 - a. Call to Order

- 2. Public Hearing – 5 Minute**
 - a. None

- 3. Agenda Review – 1 Minutes**
 - a. Agenda Review

- 4. Announcements/Recognition – 0 minutes**
 - a. None

- 5. Public Comment – 15 Minutes**
 - a. Public may address the Board

- 6. Business Requiring Discussion – 30 Minutes**
 - a. Dartmouth College Crosby Street energy project update
 - b. Deer Team presentation on proposed expanded area to Town boundaries.
 - c. Organizational meeting for 2025-2026 Selectboard and committee assignments
 - d. Statutory Boards and Committees Review
 - e. Ledyard Park presentation
 - f. Review proposed 2026 Rates and Fees Schedule

- 7. Town Manager Monthly Report – 10 Minutes**
 - a. Town Manager Report

- 8. Business Requiring Action – 60 Minutes**
 - a. Approval of May 19, 2025, Selectboard Minutes
 - b. Approval of NH Municipal Bond bank loan agreement for new fire truck (approved at 2023 Town Meeting).
 - c. Approval of Post-Issuance Tax Compliance Policies and Procedures Resolution.
 - d. Approval of item i to ii by Consent
 - i. Appointments - Deputy Town Clerk and Commissioner of Conservation Commission

- ii. Light pole banner and Main Street pennant requests

9. Selectboard Reports – 15 Minutes

10. Nonpublic Session – 20 Minutes

- a. Move into Nonpublic Session
- b. Discussion pursuant to RSA 91:1:3 II (A)(B)(D)(E)(L)

11. Adjournment

Hearing enhancement equipment is available for use by the public.

TOWN *of* HANOVER

**NOTICE OF PUBLIC MEETING
SELECTBOARD
Monday, June 2, 2025, at 7:00 PM
Board Room, Municipal Building
41 South Main Street, Hanover, NH**

AGENDA

- 1. Opening of Meeting – 1 Minute**
 - a. Call to Order

- 2. Public Hearing – 5 Minute**
 - a. None

- 3. Agenda Review – 1 Minutes**
 - a. Agenda Review

- 4. Announcements/Recognition – 0 minutes**
 - a. None

- 5. Public Comment – 15 Minutes**
 - a. Public may address the Board

- 6. Business Requiring Discussion – 30 Minutes**
 - a. Dartmouth College Crosby Street energy project update
 - b. Deer Team presentation on proposed expanded area to Town boundaries.
 - c. Organizational meeting for 2025-2026 Selectboard and committee assignments
 - d. Statutory Boards and Committees Review
 - e. Ledyard Park presentation
 - f. Review proposed 2026 Rates and Fees Schedule

- 7. Town Manager Monthly Report – 10 Minutes**
 - a. Town Manager Report

- 8. Business Requiring Action – 60 Minutes**
 - a. Approval of May 19, 2025, Selectboard Minutes
 - b. Approval of NH Municipal Bond bank loan agreement for new fire truck (approved at 2023 Town Meeting).
 - c. Approval of Post-Issuance Tax Compliance Policies and Procedures Resolution.
 - d. Approval of item i to ii by Consent
 - i. Appointments - Deputy Town Clerk and Commissioner of Conservation Commission

- ii. Light pole banner and Main Street pennant requests

9. Selectboard Reports – 15 Minutes

10. Nonpublic Session – 20 Minutes

- a. Move into Nonpublic Session
- b. Discussion pursuant to RSA 91:1:3 II (A)(B)(D)(E)(L)

11. Adjournment

Hearing enhancement equipment is available for use by the public.

TOWN of HANOVER

MEMORANDUM

TO: Selectboard Members
FROM: Robert Houseman, Town Manager
DATE: JUNE 2, 2025

SUBJECT: Information for the Selectboard for June 2, 2025

Business Requiring Discussion

a. Dartmouth College Crosby Street energy project update

Please see additional information included in the Selectboard meeting materials packet.

This presentation aims to inform the Selectboard and the Town about an upcoming Dartmouth College project that will require the closure of Crosby Street and include the implementation of a coordinated traffic management plan. It is important to note that Dartmouth College has collaborated closely with key Town staff and the Hanover School Districts over several months to develop this plan. The plan includes strategies to minimize the impact of the road closure, including rerouting public school buses and coordinating with emergency services. Finally, Dartmouth has committed to future enhancements to the public right-of-way, designed in collaboration with the Town and aligned with Hanover's multimodal transportation goals. The yet to be designed improvements will consider the Town's broader transportation planning efforts, including the Safe Streets for All initiative.

b. Deer Team presentation on proposed expanded area to Town boundaries

Hanover has collaborated with the New Hampshire Fish and Game Department (NHFG) to obtain additional doe hunting permits due to deer overpopulation. This has been accomplished through the Special Deer Management Area (DMA) process established by NHFG.

It is unclear what steps will be necessary to expand the DMA to the Town Boundaries, or whether written landowner permission will still be required. A map of all the landowner-authorized parcels must currently be submitted to NHFG and distributed with all permits. If written landowner authorization and parcel mapping are necessary, this will require additional staff time and resources. Currently, the process involves Alex Taft, Senior Planner; Kate Shea, Town Manager's Administrative Assistant; and the Town Clerk's Office, who spend approximately 40-60 hours seasonally preparing all the documents and issuing the permits. Additionally, the mapping is prepared by Dartmouth College.

Finally, Town Staff is working on filing the annual NHFG application by mid-June, so any changes in the boundaries may need to be postponed until next year.

c. Organizational meeting for 2025-2026 Selectboard and Committee assignments

- Election of Officers
 - Chair
 - Vice Chair
 - Secretary
- Board/Committee Assignments
 - See attached chart for Board assignments.

d. Statutory Boards and Committees Review

As requested, a chart of all Town Boards is included in the Selectboard meeting materials packet.

e. Ledyard Park Presentation

Please see additional information included in the Selectboard meeting materials packet.

f. Review proposed 2026 Rates and Fees Schedule

Rates and Fees Schedule will be sent in a separate email.

Town Manager Monthly Report

Please see this report included in the Selectboard meeting materials packet.

Business Requiring Action

a. Approval of May 19, 2025, Selectboard Minutes

Action Requested: Approve May 19, 2025, Selectboard minutes.

Suggested Motion: *I move to approve May 19, 2025, Selectboard minutes as written.*

b. Approval of NH Municipal Bond bank loan agreement for the new fire truck (the bond was authorized at the 2023 Town Meeting).

Action Requested: Approve the NH Municipal Bond bank loan agreement for the new fire truck (the bond was authorized at the 2023 Town Meeting).

Suggested Motion: *I move to approve the NH Municipal Bond bank loan agreement for the new fire truck (the bond was authorized at the 2023 Town Meeting).*

c. Approval of Post-Issuance Tax Compliance Policies and Procedures Resolution

Action Requested: Approve the resolution of the Post-Issuance Tax Compliance Policies and Procedures Resolution.

Suggested Motion: *I move to approve the Post-Issuance Tax Compliance Policies and Procedures resolution, attached, and that the Board names the Director of Finance as the "Coordinator" under the Post-Issuance Tax Compliance Policies, and that the Director of Finance has accepted such nomination, and finally that this resolution shall take effect from and after its adoption.*

d. Approval of items i to ii by Consent

- i. Appointments
 - o Amy Haak Commissioner of Conservation Commission
 - o Bobbie Hitchcock Deputy Town Clerk
- ii. Light pole banner and Main Street pennant requests
 - o To bring awareness and support to the 44th annual Prouty

Action Requested: Approve Consent Agenda as presented.

Suggested Motion: *I move to approve the Consent Agenda as presented.*



Crosby St. Closure Coordination



Hanover Selectboard Presentation 06.02.2025

Meeting Agenda



- Introductions
- Dartmouth Energy Transition Overview
- Distribution Piping: High Level View – 5 Years
- Crosby Street Work
- Town Coordination and Commitments
- Logistics Plan Overview
 - Challenges and Mitigation Strategies
- Traffic Study
 - Findings and Recommendations
 - Suggested Bus Routes
- Communications
- Questions

Introductions

Erik Bray

Senior Director, Energy Transition

Julia Pfeiffer

Assistant Director, Energy Transition

David Anderson

Senior Planner, Campus Planning Office



Dartmouth Energy Transition Overview

Dartmouth Climate Collaborative: Four Pillars of Action

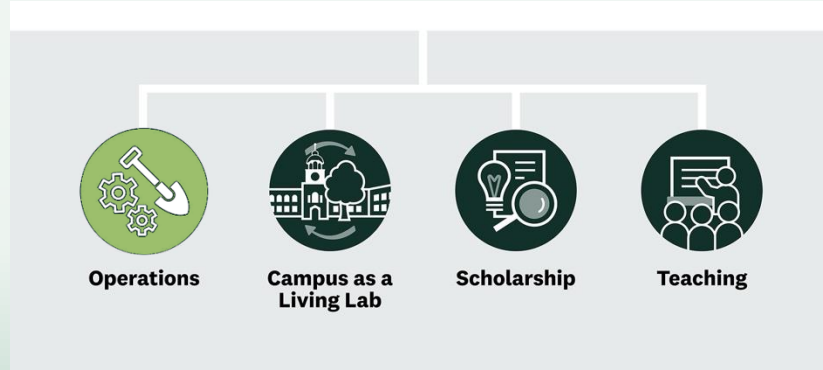

The collaborative will connect, strengthen, and leverage Dartmouth's existing work on climate and sustainability. We will invest more than \$500 million in climate-related capital improvements, with campus becoming a living lab as the projects become drivers of new research, teaching, and collaboration. Greener together.

Dartmouth Energy Transition Overview

Operations Focus and Goals

1. Renewal/replacement of aging campus heating and cooling infrastructure
2. Improved electrical, heating and cooling resilience
3. Provision of heating, cooling and electrical service to future new buildings
4. Significant and permanent reductions in energy use/cost and carbon emissions



Efficient Heating & Cooling



Energy Usage Reduction



**60% Greenhouse Gas
Reduction**

Dartmouth Energy Transition Overview

Programmatic Elements and Operation

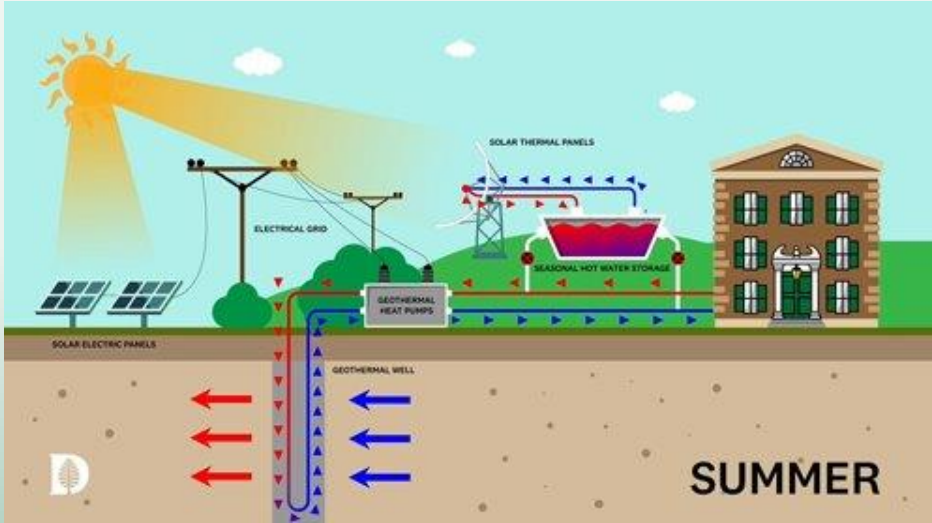

Distribution Piping: High Level View – 5 Years

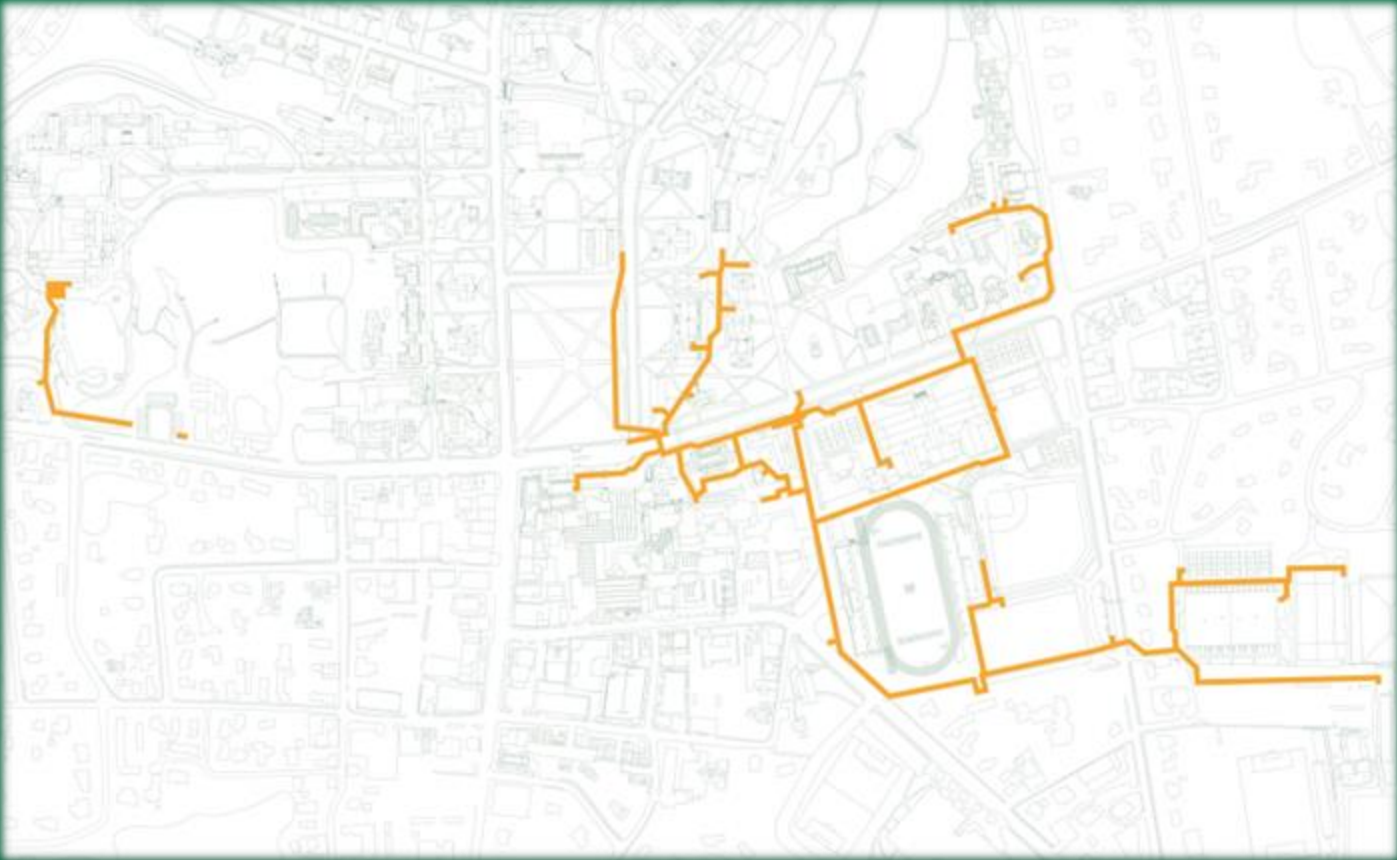

Crosby St. Work

- Proposed closure duration
 - Up to 18 months, starting 06.18.25
- Installation work needed:
 - Vault
 - Duct bank
 - Piping
 - Sewer

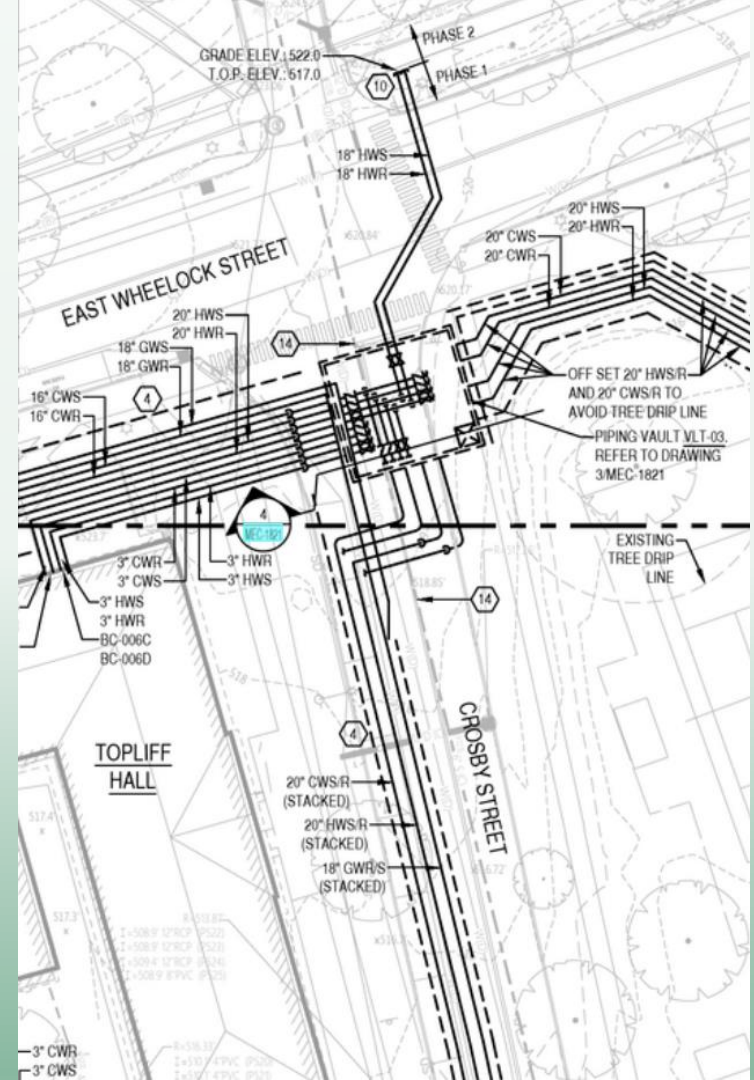

Town Coordination/Commitments

- Dartmouth has pre-coordinated with the following groups in town to prepare for permit submissions
 - Public Works – Peter Kulbacki
 - Police and Parking – Sgt. Christopher Swain and Director Douglas Hackett
 - Planning and Zoning – Ryan Borkowski
 - Fire Department – Deputy Fire Chief Josh Merriam
 - Town Manager – Robert Houseman
 - Hanover School Administration
- Licensing
 - Dartmouth will enter into a licensing agreement for utilities in the public right of way
- Restoration
 - Restoration will be coordinated with the Town of Hanover Public Works Director and Town Manager
- Parking
 - Contractors for this project will park remotely
 - Dartmouth will purchase all parking spots within restricted areas
- Safety/Risk Mitigation
 - There will be a full-time logistics manager working under the contractor to ensure the full logistics plan is followed correctly
 - Dartmouth safety department will perform regular site walks



Logistics Plan Overview

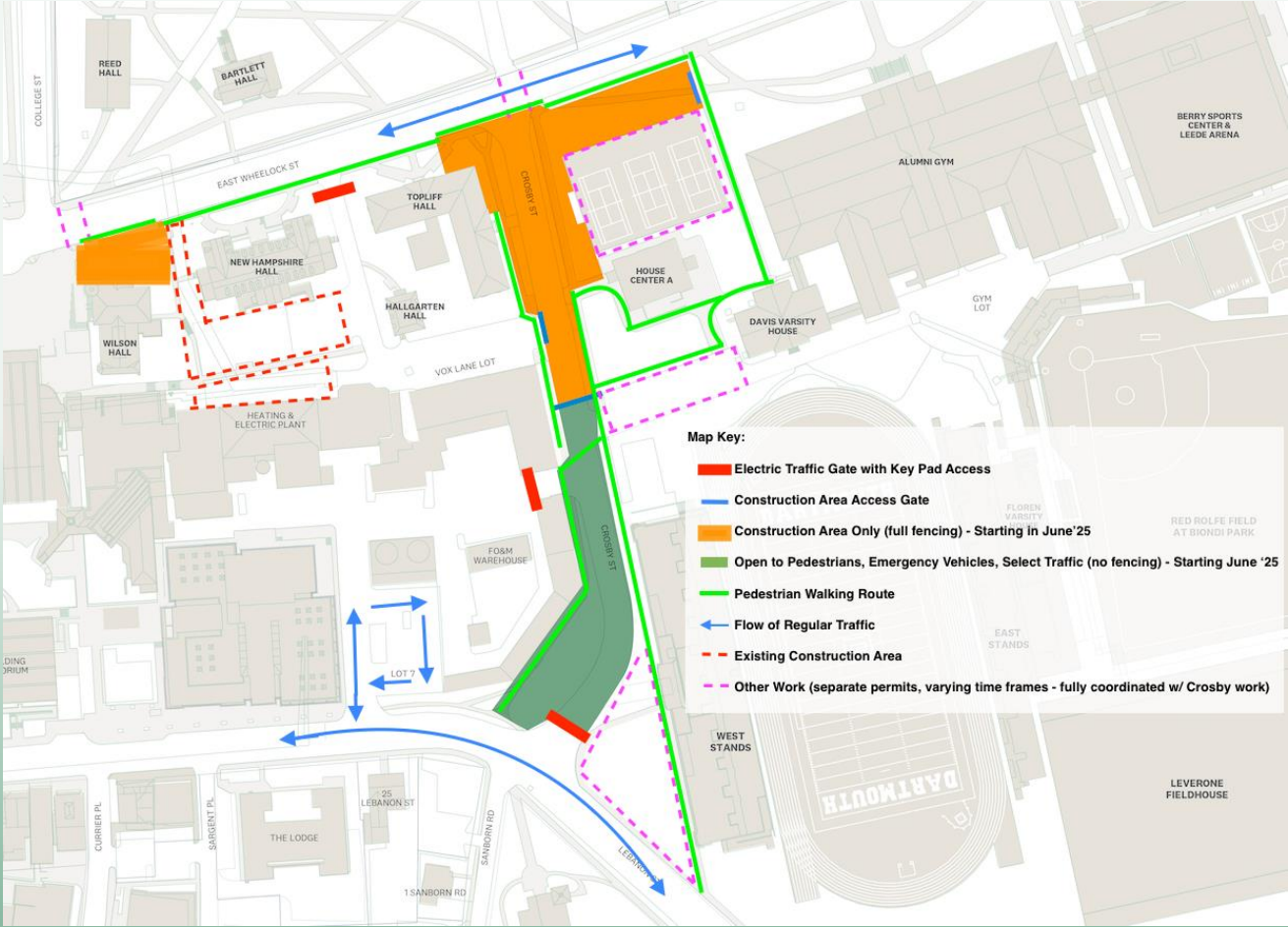

Logistics Plan Overview – Challenges and Mitigations

Identified Challenge	Mitigation Strategy
Confusion for pedestrians	Create full signage plan for pedestrian routes
Confusion for motorists	Create full signage plan for immediate area and further distance
Potential bottleneck at north end of Crosby	Close full road to vehicle traffic, not just northern section
Emergency vehicle and fire access	Engage specialty consultant for full emergency plan
Selective vehicle access	Install temporary gates for selective access
Bus route impacts	Engage Erica Wygonik from Wall Consultant Group for recommendations
2024 – 2025 school year impact	Closure is scheduled to occur after public school year 2024-2025 completes



Traffic Study: Findings and Recommendations

- Evaluated Congestion at 5 Major Intersections:
 - Main & Wheelock
 - Main & Lebanon
 - Lebanon & Park (Co-op)
 - Park & Wheelock
 - Lyme/College/Park
- Evaluation showed minimal change in delay with no change is LOS (Level of Service) rating



Key:
Existing / Crosby Detour AM LOS
Existing / Crosby Detour PM LOS



Traffic Study: Suggested School Bus Routes

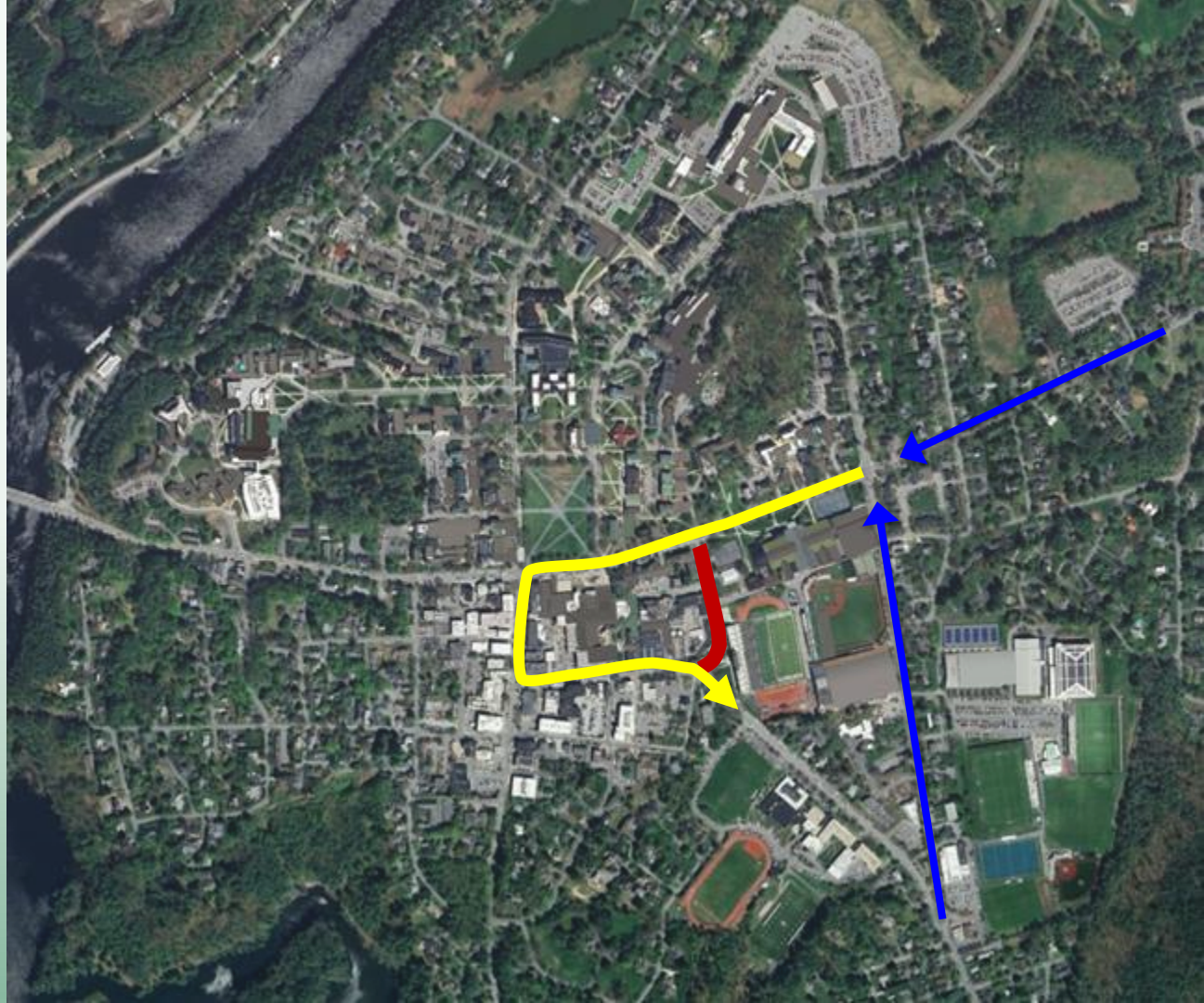

Traffic Study: Suggested School Bus Routes

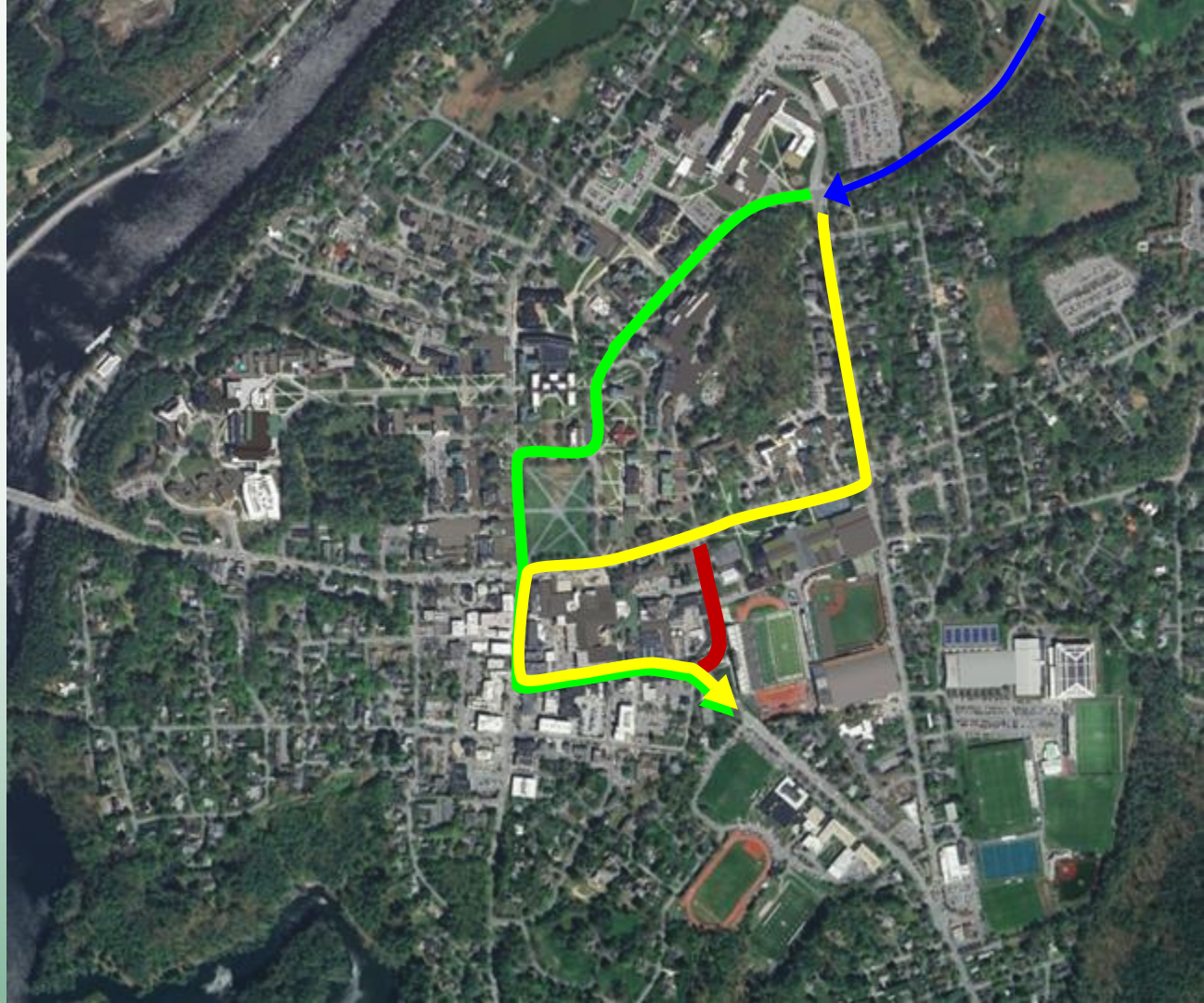

Communications

- There will be a dedicated web page for the Crosby Street work
 - Updates will be posted regularly
- Site Signage
 - Posted signs will direct calls to Facilities Customer Service Center for 24/7 response
- Press Release
 - Proposed Valley News announcement and supporting article



Questions and Open Discussion

 Thank you

Statutory Boards and Committees

Board / Committee	Type	Selectboard Member Assignment
Selectboard	Statutory	
Advisory Board of Assessors	Statutory	
Capital Improvement Program Committee	Statutory	
Conservation Commission	Statutory	
Planning Board	Statutory	
Howe Library Board of Trustees	Independent	
Sustainable Hanover Committee	Advisory	
• <i>Energy Subcommittee</i>	Advisory	
• <i>Recycling Subcommittee</i>	Advisory	
• <i>Sustaining Landscapes Subcommittee</i>	Advisory	
Hanover Walk/Bike Committee	Advisory	

Board / Committee	Type	Selectboard Member Assignment
Hanover Finance Committee	Advisory	
Trails Committee <i>(Conservation Commission subcommittee)</i>	Advisory (Subcommittee)	
Biodiversity Committee <i>(Conservation Commission subcommittee)</i>	Advisory (Subcommittee)	

Statutory Boards and Committees

Board / Committee	Type	Selectboard Role
Selectboard	Statutory	Full voting member
Advisory Board of Assessors	Statutory	Liaison – One Selectboard member liaison and a Selectboard alternate (statute).
Capital Improvement Program Committee	Statutory	Two Selectboard members serve as full voting members of the committee (bylaws and statute).
Conservation Commission	Statutory	One Selectboard member serves as a full voting member (bylaws).
Etna Library Board of Trustees	Statutory	None – it is composed of elected Library Trustees.
Planning Board	Statutory	Ex Officio Voting Member – One Selectboard member serves as a full voting member ex officio, with another as alternate to the ex officio member (statute).
Supervisors of the Checklist	Statutory	None – Supervisors are independently elected officials (statute).
Trustees of Trust Funds	Statutory	Liaison – No Selectboard on this elected Board (statute).
Zoning Board of Adjustment	Statutory	None – Selectboard members do not serve on the ZBA (statute).
Cemetery Trustees (Board of Cemetery Trustees)	Statutory	None – it is composed of elected Cemetery Trustees.

Non-statutory Board

Board / Committee	Type	Selectboard Role
Howe Library Board of Trustees	Independent	Liaison – One Selectboard member liaison and one Selectboard alternate Liaison.

Advisory Boards, Committees, and Subcommittees

Board / Committee	Type	Selectboard Role
Sustainable Hanover Committee	Advisory	Selectboard Representatives (voting members) – One Selectboard members serve as a full member of the committee (no bylaws posted).
<ul style="list-style-type: none"> • <i>Energy Subcommittee</i> 	Advisory	The Selectboard Representative can be a member. This subcommittee is also responsible for approving electric rates and is appointed by the Selectboard.
<ul style="list-style-type: none"> • <i>Recycling Subcommittee</i> 	Advisory	The Selectboard Representative can be a member.
<ul style="list-style-type: none"> • <i>Sustaining Landscapes Subcommittee</i> 	Advisory	The Selectboard Representative can be a member.
Building Code Advisory Committee	Advisory	The committee is composed of residents and experts.
Hanover Walk/Bike Committee	Advisory	Up to two <i>ex officio</i> Selectboard representatives (bylaws).

Board / Committee	Type	Selectboard Role
Hanover Community Nursing Advisory Committee	Advisory	The committee includes Town staff and community representatives; there is no Selectboard liaison.
Hanover Finance Committee	Advisory	Selectboard Representative (voting member) – One Selectboard member serves on the committee, with another as an alternate representative.
Minor Projects Review Committee	Advisory	The committee comprises Town staff, delegated by the Planning Board.
Trails Committee (<i>Conservation Commission subcommittee</i>)	Advisory (Subcommittee)	The Selectboard Representative can be a member.
Biodiversity Committee (<i>Conservation Commission subcommittee</i>)	Advisory (Subcommittee)	The Selectboard Representative can be a member.

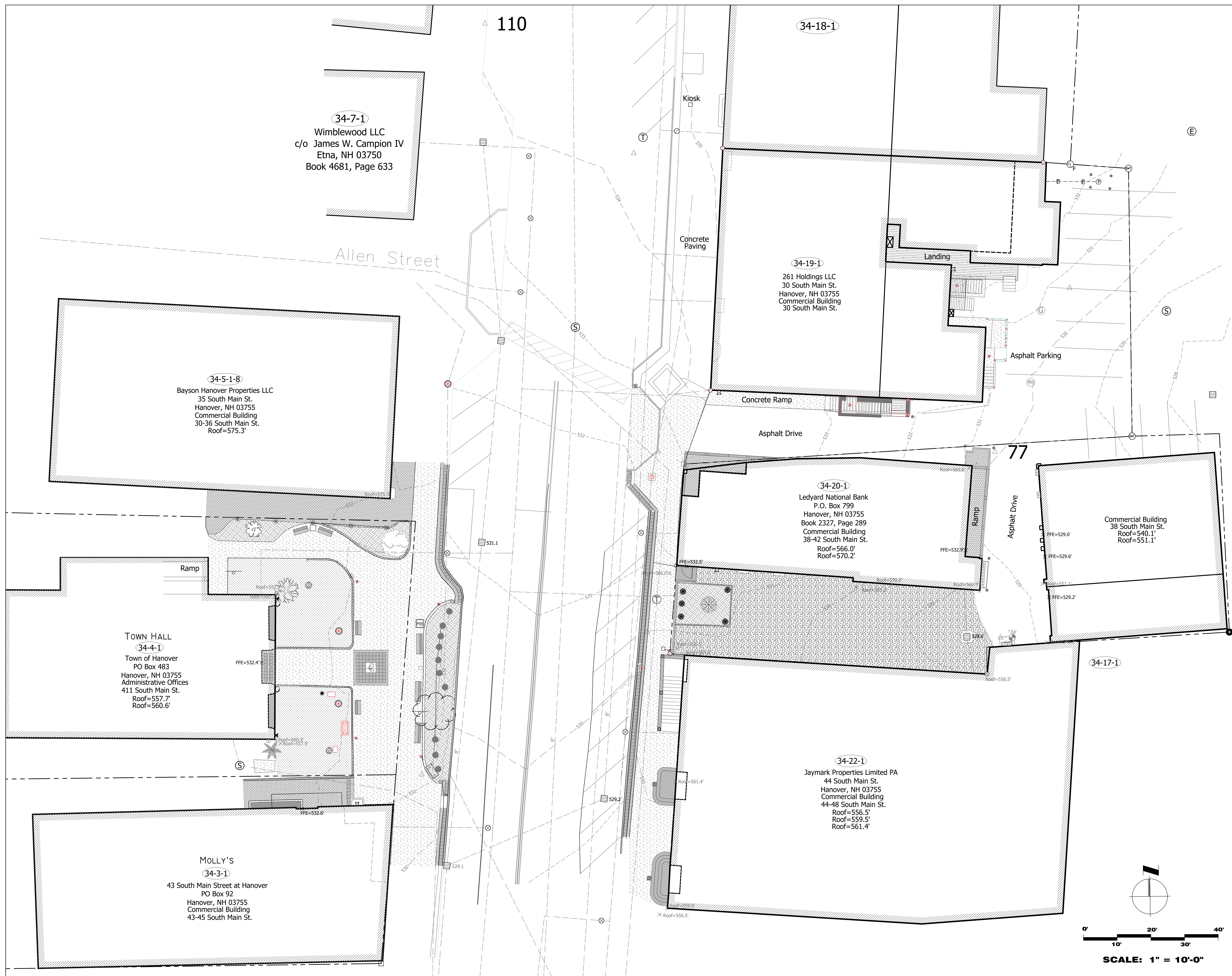

34-7-1
Wimblewood LLC
c/o James W. Campion IV
Etna, NH 03750
Book 4681, Page 633

34-5-1-8
Bayson Hanover Properties LLC
35 South Main St.
Hanover, NH 03755
Commercial Building
30-36 South Main St.
Roof=575.3'

TOWN HALL
34-4-1
Town of Hanover
PO Box 483
Hanover, NH 03755
Administrative Offices
411 South Main St.
Roof=557.7'
Roof=560.6'

MOLLY'S
34-3-1
43 South Main Street at Hanover
PO Box 92
Hanover, NH 03755
Commercial Building
43-45 South Main St.

34-19-1
261 Holdings LLC
30 South Main St.
Hanover, NH 03755
Commercial Building
30 South Main St.

34-20-1
Ledyard National Bank
P.O. Box 799
Hanover, NH 03755
Book 2327, Page 289
Commercial Building
38-42 South Main St.
Roof=566.0'
Roof=570.2'

Commercial Building
38 South Main St.
Roof=540.1'
Roof=551.1'

34-22-1
Jaymark Properties Limited PA
44 South Main St.
Hanover, NH 03755
Commercial Building
44-48 South Main St.
Roof=556.5'
Roof=559.5'
Roof=561.4'

34-17-1

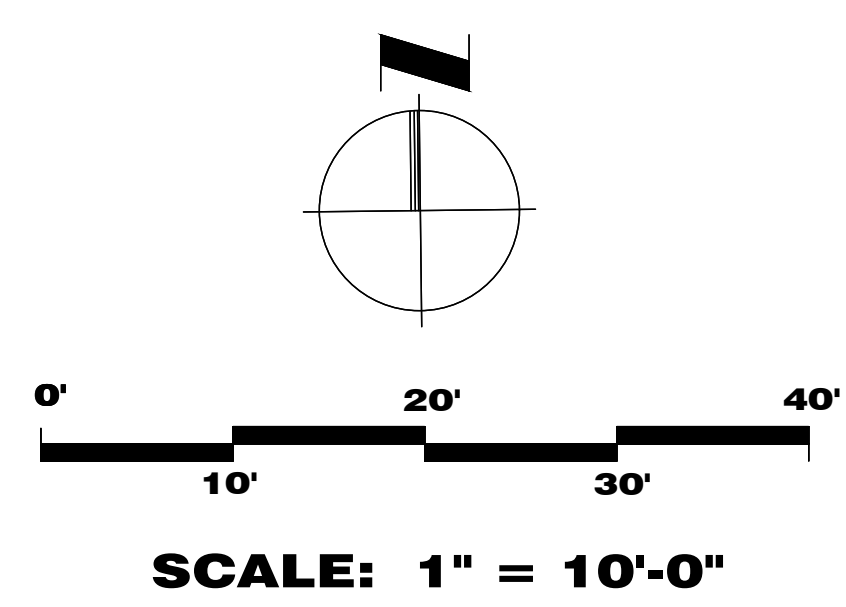

PROGRESS SET
NOT FOR CONSTRUCTION

Issued
NOT FOR CONSTRUCTION

05/16/25
PROGRESS

MARK	DATE	DESCRIPTION

Project
LEDYARD PARK
S. MAIN STREET HANOVER NH 03755 US
Project No.: 25105 | PA 2318
Sheet Title

EXISTING SURVEY

L1.0
© Copyright - Park Architecture, LLC, 2025

EXISTING CONDITIONS PHOTOS

NOT TO SCALE



VIEW FROM LEDYARD BANK SIDE ENTRANCE
MULCH BED AND ALL PLANTINGS TO BE REMOVED. ALL GRANITE
POSTS, PAVERS, AND EDGING TO BE REMOVED, SEE SHEET L1.1



MAINTAIN CLEAR ACCESS TO EXISTING DRY HYDRANT
ON LEDYARD BANK BUILDING, SEE SHEET L2.0



VIEW FROM MAIN STREET ENTRANCE
GRAVEL TO BE REMOVED, SEE SHEET L1.1



VIEW FROM MAIN STREET ENTRANCE
MULCH BED, ALL PLANTINGS, AND ALL GRANITE POSTS,
PAVERS, AND EDGING TO BE REMOVED, SEE SHEET L1.1



VIEW FROM MAIN STREET
4"X8" AND 12"X12" PAVERS TO REMAIN. VERTICAL CURB, CONCRETE, MULCH BED,
ALL PLANTINGS, AND ALL GRANITE POSTS AND PAVERS TO BE REMOVED.
SEWER MAN HOLE TO BE RESET AT EXISTING GRADE. SEE SHEET L1.1

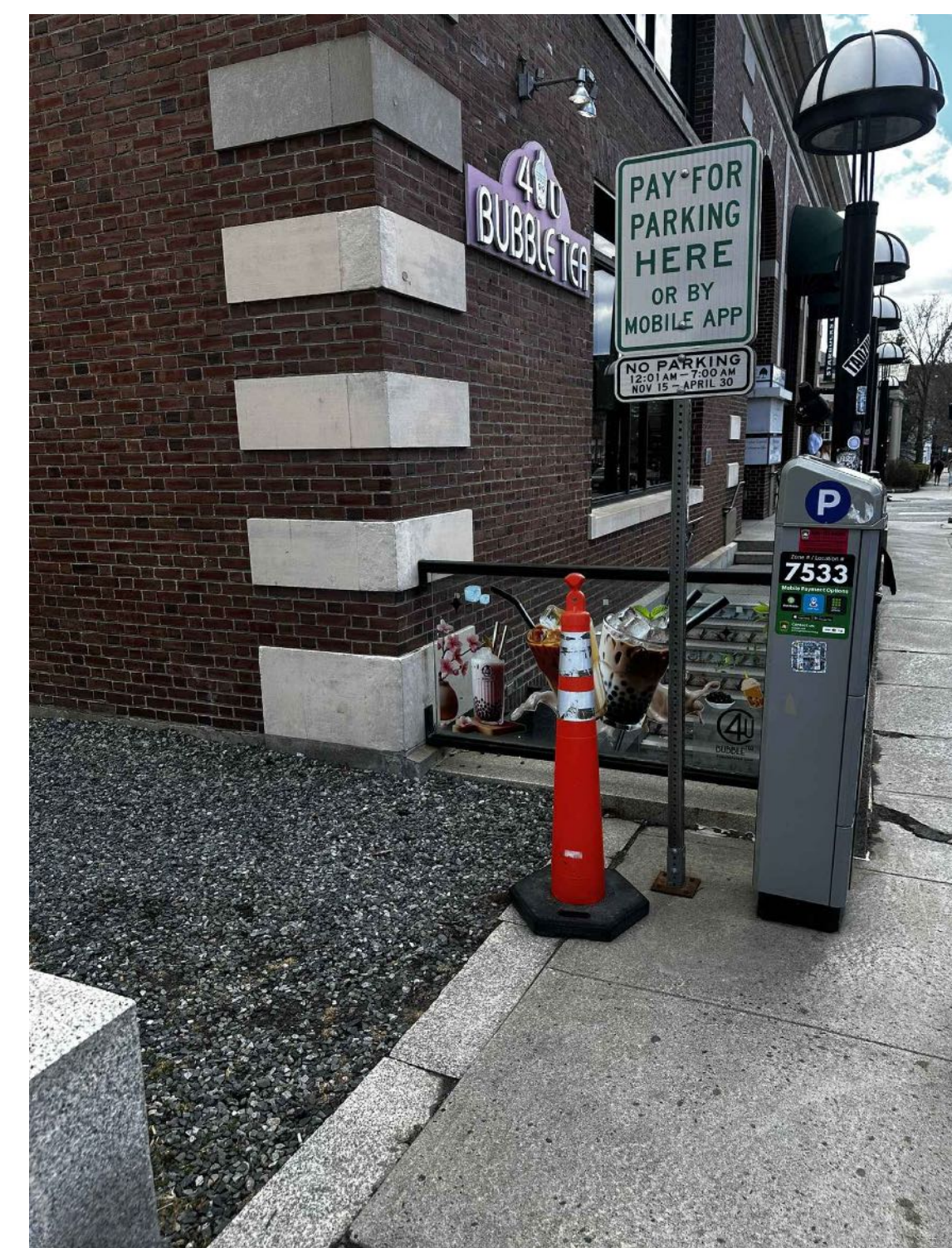

EXISTING PARKING SIGN AND KIOSK TO REMAIN



EXISTING ELECTRICAL ENCLOSURE FOR
LEDYARD BANK AT BACK ENTRANCE OF PARK

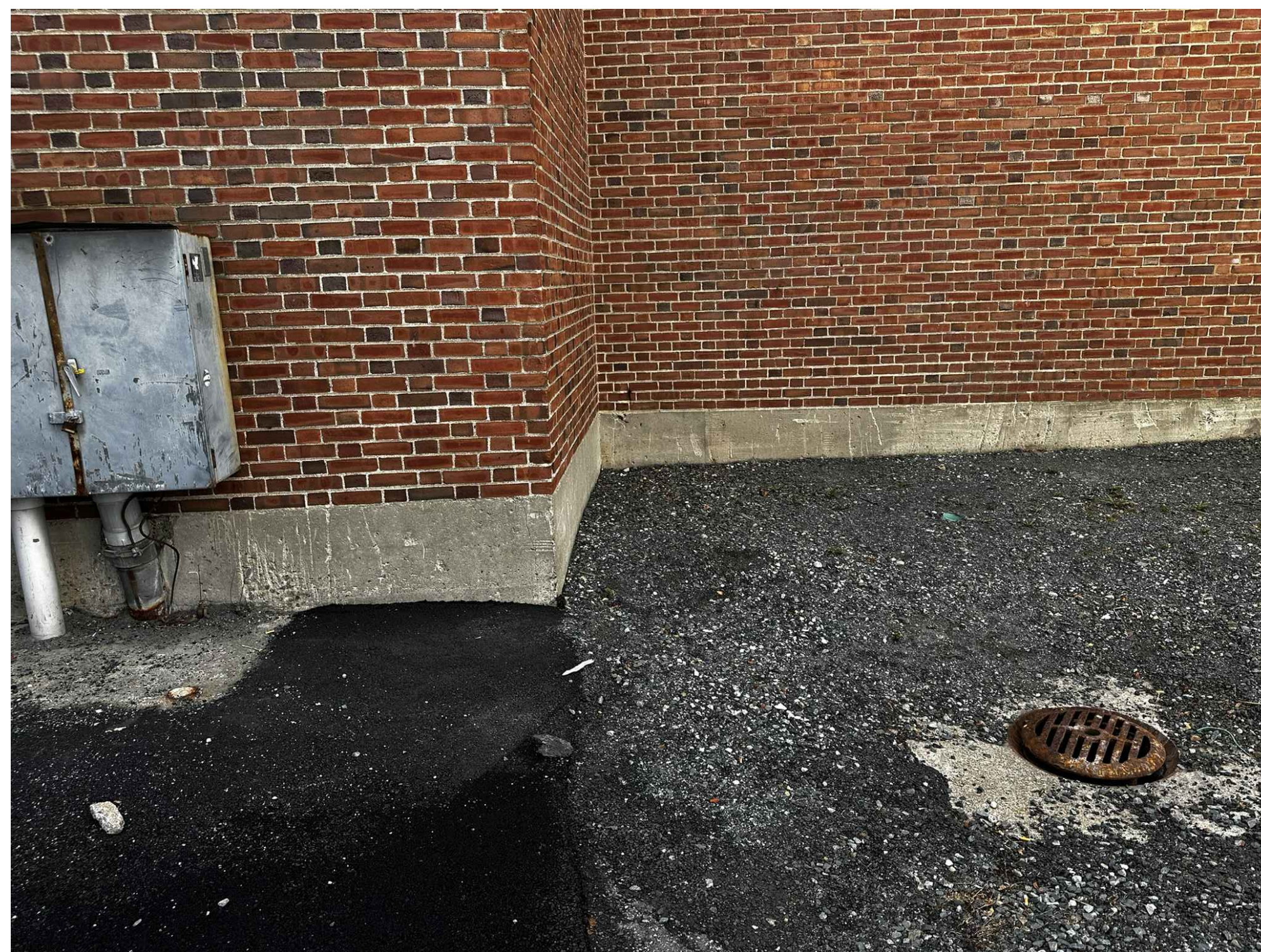

EXISTING CATCH BASIN TO BE INSPECTED AND GRATE REPLACED WITH NEW (DMH)
DRAINAGE MAN HOLE OR REPLACED ENTIRELY WITH A NEW DMH, SEE SHEET L1.1

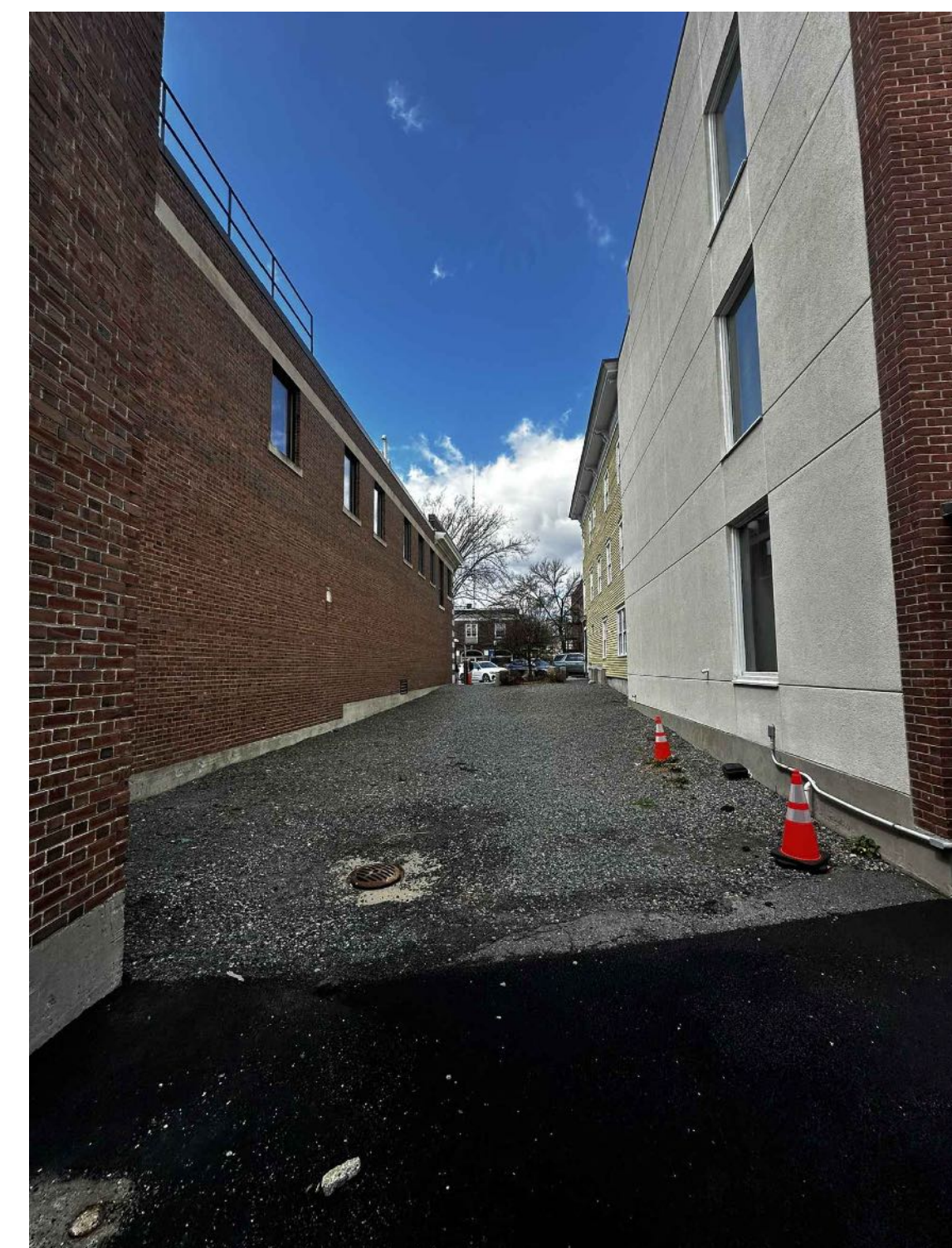

VIEW FROM BACK ENTRANCE TO MAIN STREET



53 S Main Street, Suite 204
P.O. Box 231
Hanover NH 03755
p: 603 643 8868
www.ma-ke-arch.com



3 School House Lane, Suite #1 Etra NH
Tel: 603-643-3400 Mobile: 617-905-0467
Email: parkarchitecture@gmail.com

**PROGRESS SET
NOT FOR CONSTRUCTION**

Issued

NOT FOR CONSTRUCTION

05/16/25

PROGRESS

MARK DATE DESCRIPTION

MARK	DATE	DESCRIPTION

Project

LEDYARD PARK

S. MAIN STREET HANOVER NH 03755 US

Project No.: 25105 | PA 2318

Sheet Title

**EXISTING CONDITIONS
SITE PHOTOS**

L1.2

© Copyright - Park Architecture, LLC, 2025

PROGRESS SET
NOT FOR CONSTRUCTION

NOT FOR CONSTRUCTION

05/16/25
PROGRESS

MARK DATE DESCRIPTION

Project

LEDYARD PARK

S. MAIN STREET HANOVER NH 03755 US
Project No.: 25105 | PA 2318
Sheet Title

SITE LANDSCAPE PLAN

L3.0

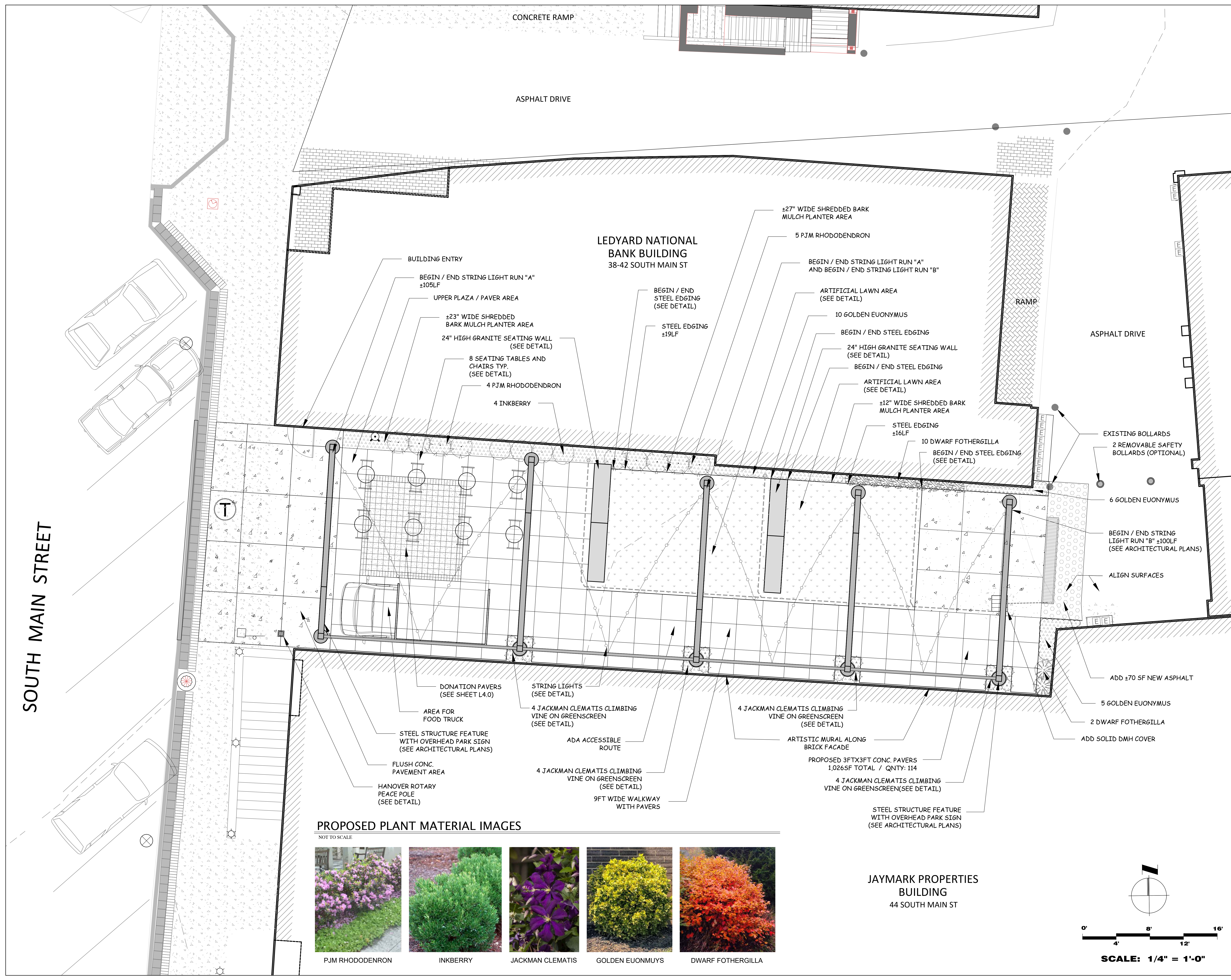

PROPOSED PLANT MATERIAL IMAGES
NOT TO SCALE

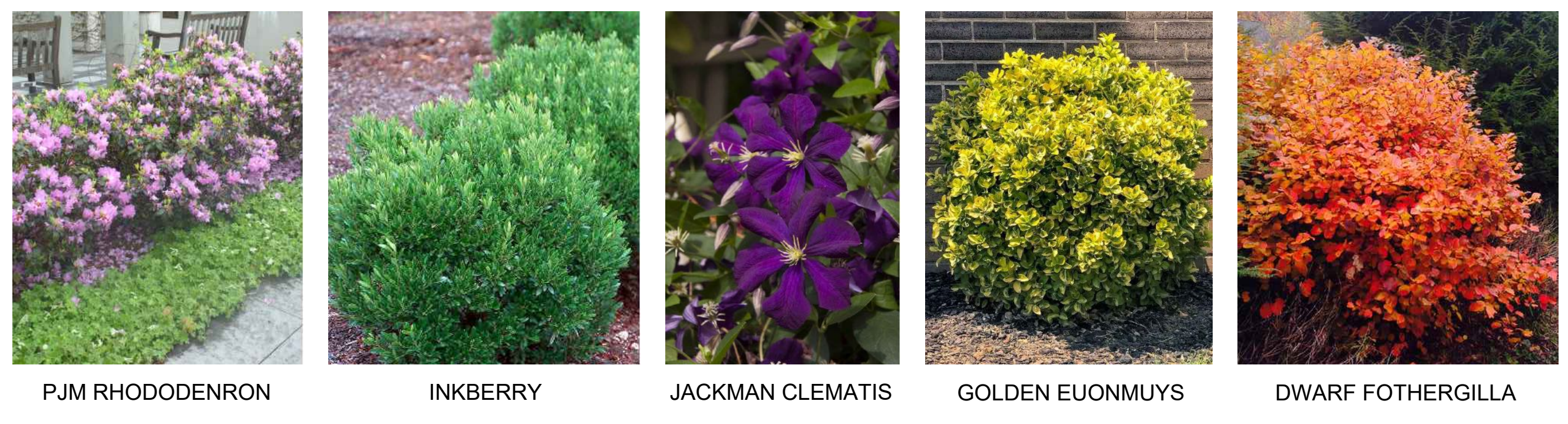

PJM RHODODENRON INKBERRY JACKMAN CLEMATIS GOLDEN EUONMUYS DWARF FOTHERGILLA

JAYMARK PROPERTIES
BUILDING
44 SOUTH MAIN ST

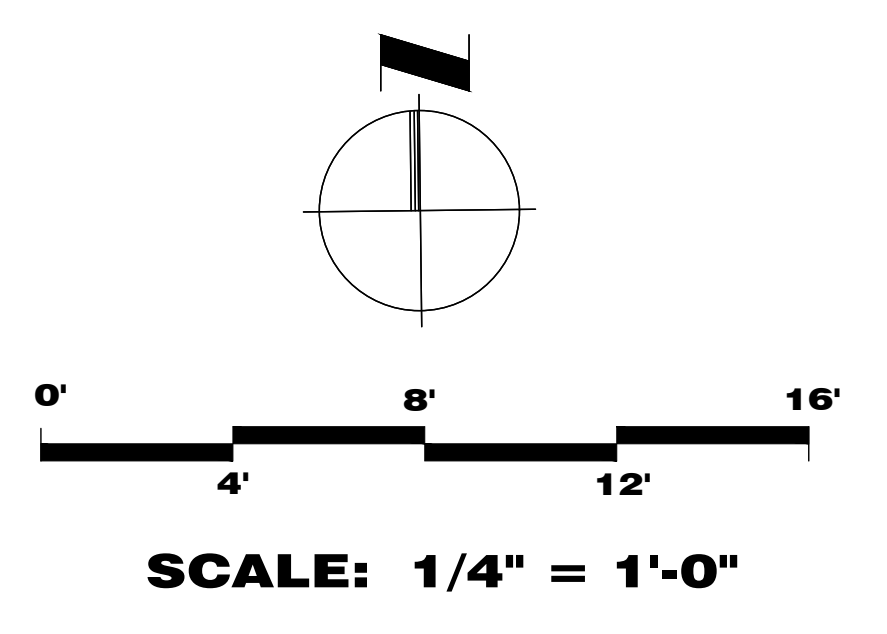

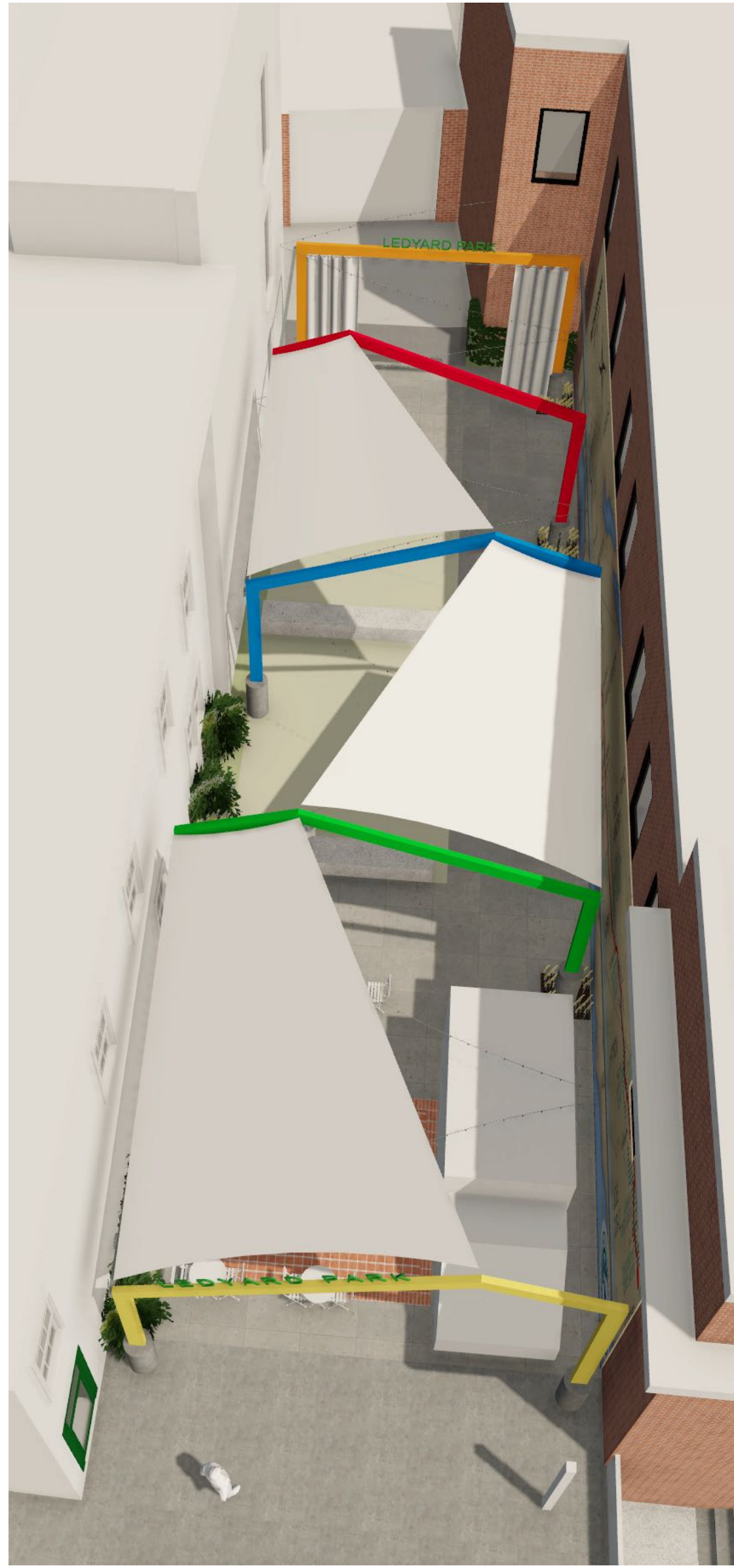

SUMMER



WINTER

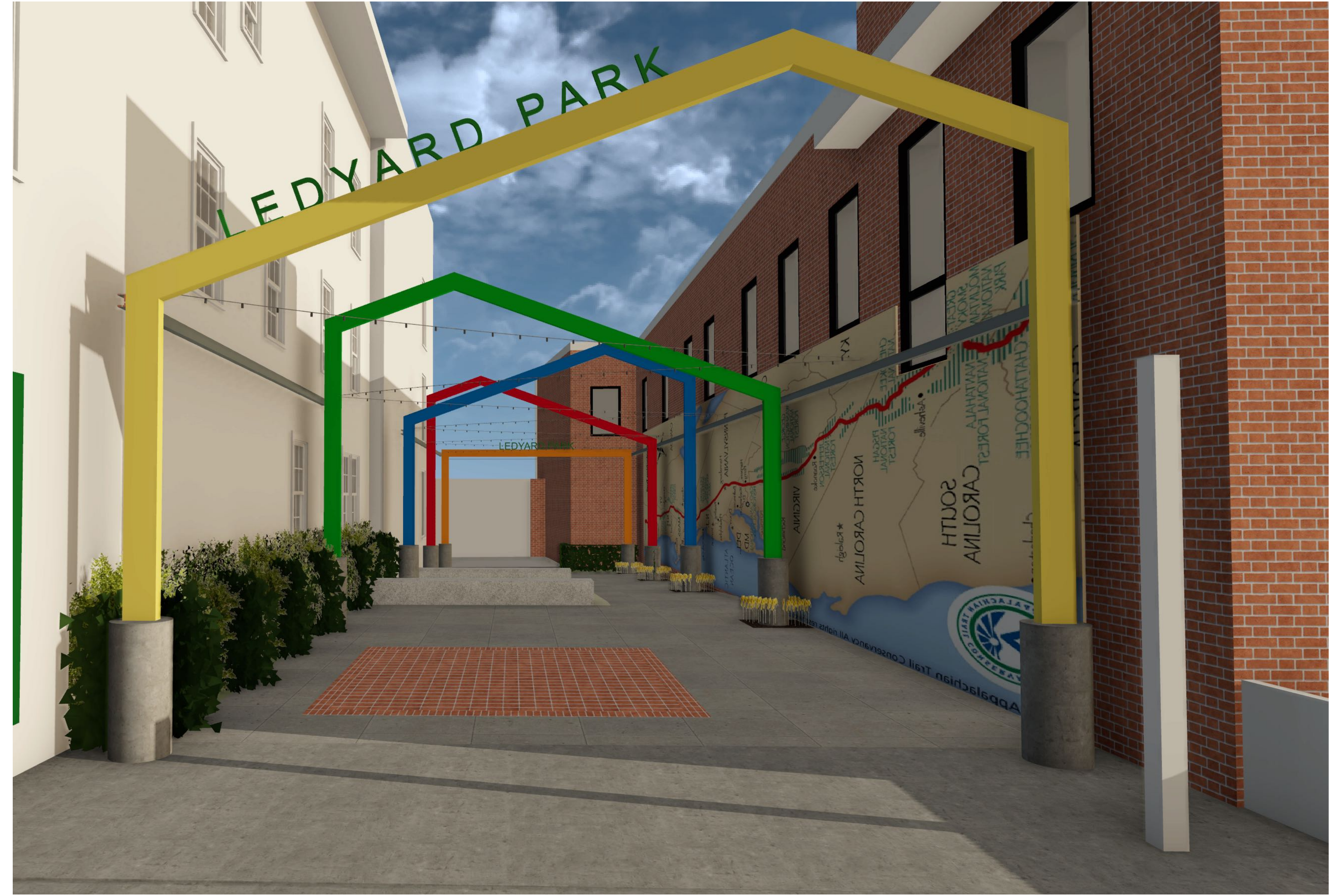

WINTER



SUMMER



SUMMER



**PROGRESS SET
NOT FOR CONSTRUCTION**

Issued

NOT FOR CONSTRUCTION

5/9/25

PROGRESS

Project

LEDYARD PARK

S. MAIN STREET HANOVER NH 03755 US

Project No.: 25105

Sheet Title

3D VIEWS

A9-04

DONATION PAVER SPECIFICATIONS



1.800.344.LASER

BELDEN BRICK COLORS

Available in 4" x 8" x 2 1/4" and 8" x 8" x 2 1/4" pavers

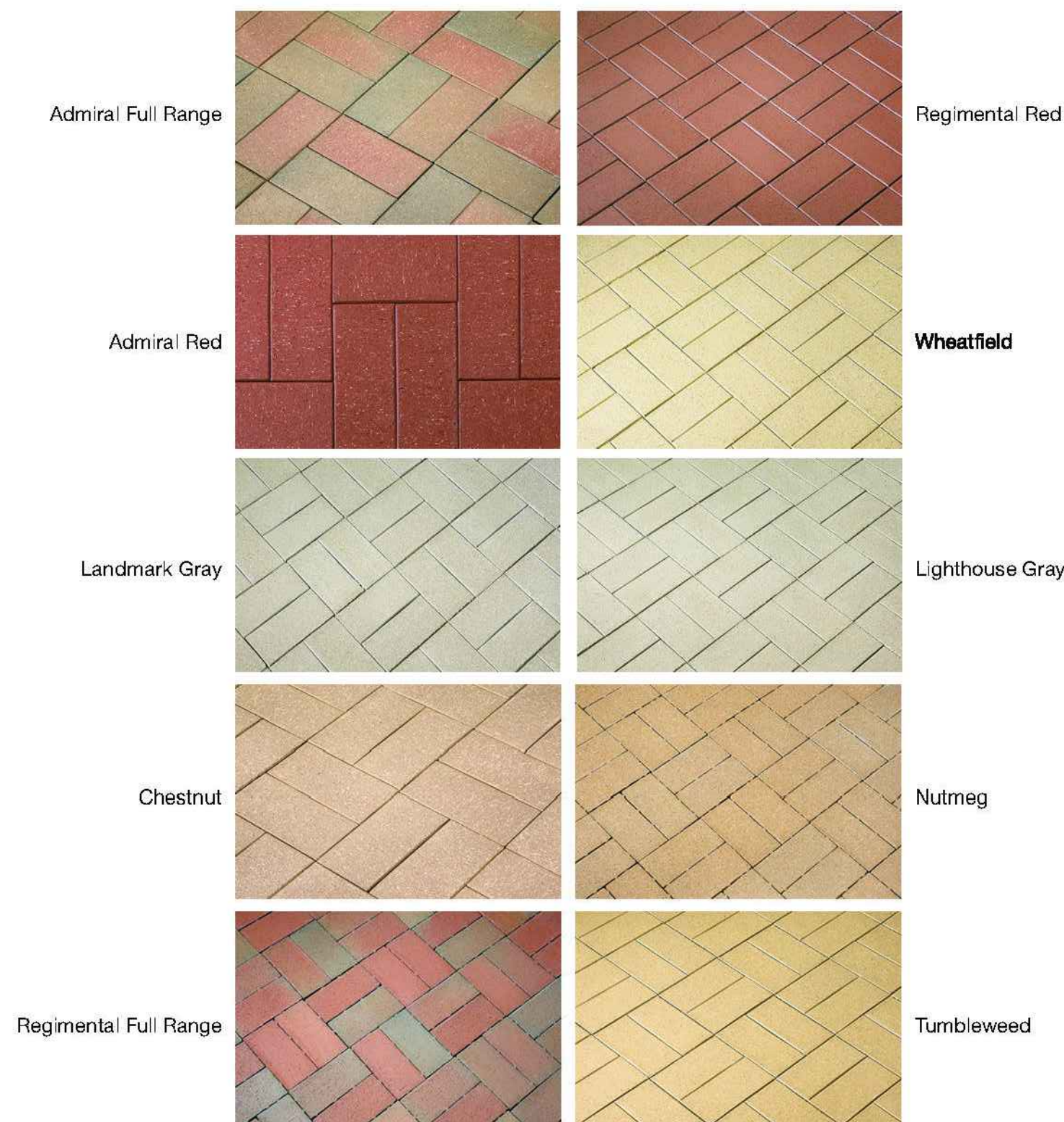

DONATION PAVER COLOR SELECTION

- COLOR #1 FOR 4" X 8" HEADER COURSE = _____
- COLOR #2 FOR 8" X 8" INTERIOR PAVERS = _____
- PAVER COLOR SELECTIONS TO BE SELECTED BY OWNER.

DONATION PAVER TEXT STYLE / FONT OPTIONS

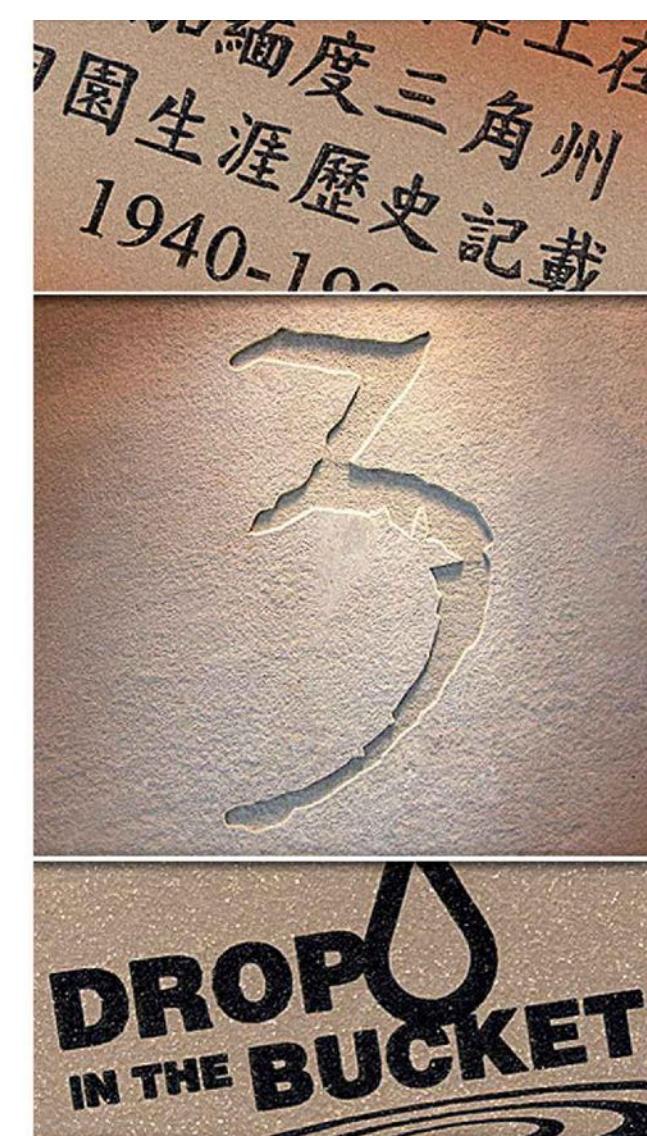

Fonts
Design Center | Fonts | Clip Art | Logos | Image Arrays | Children's Artwork

The font you choose for your project will ultimately become the voice of your donor. The following fonts have excellent readability, individuality and universal aesthetic appeal. If you have another font in mind, please let us know. We can laser engrave any true type font.

Click to preview any of the font names below:

Arial	Comic Sans	Myriad Web	Verdana
Arrus	Dutch	Papyrus	Zapf Humanist
Avenir	Futura Book	Square	
Book Antiqua	Garamond	Tahoma	

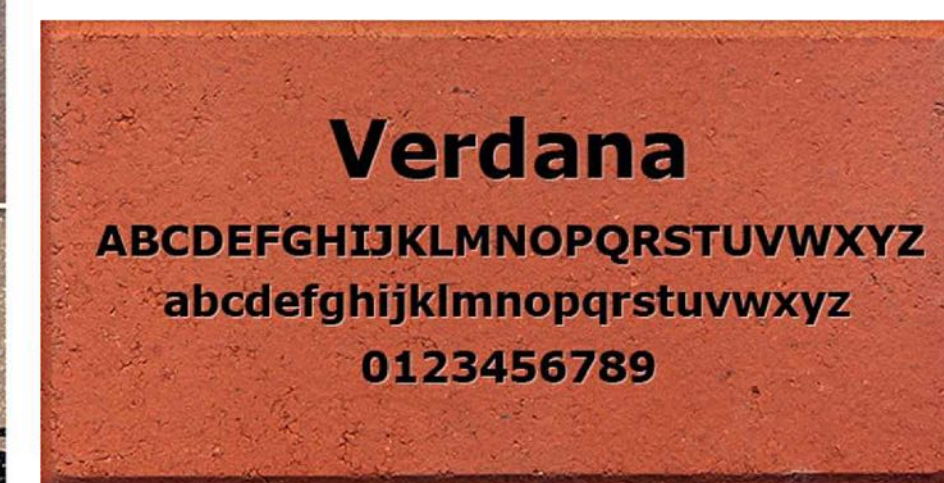

DONATION PAVER NOTES

- ENGRAVED TEXT ORIENTED TO BE READ FROM MAIN STREET
- TEXT STYLE / FONT TYPE TO BE SELECTED BY OWNER.
- BRICKS BY BELDEN BRICKS. WEB: ENGRAVEDBRICKS.COM

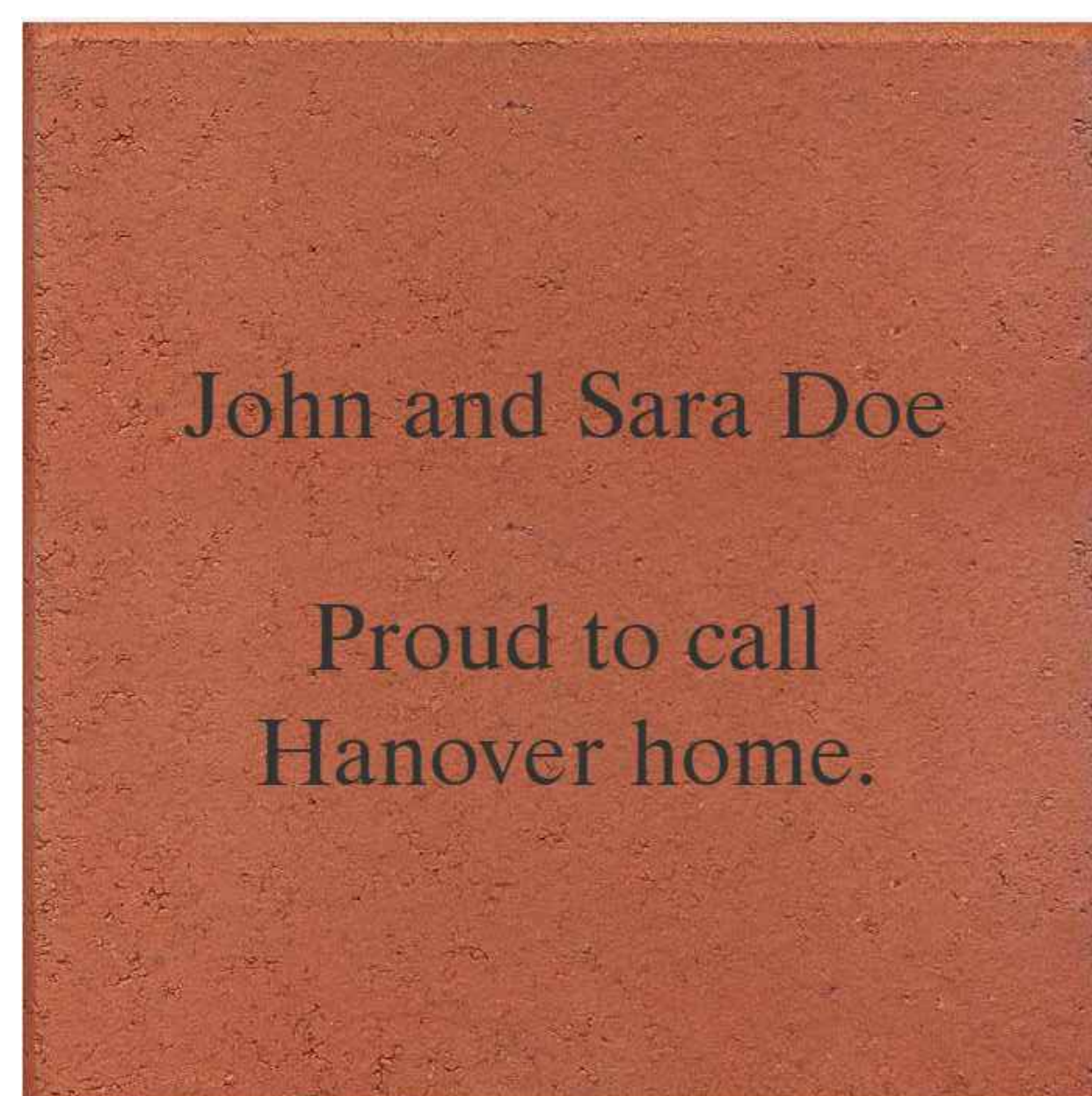

DONATION PAVER ENLARGEMENT PLAN (12'-0" WIDE X 12'-0" LONG)

SCALE: 1" = 1'-0"

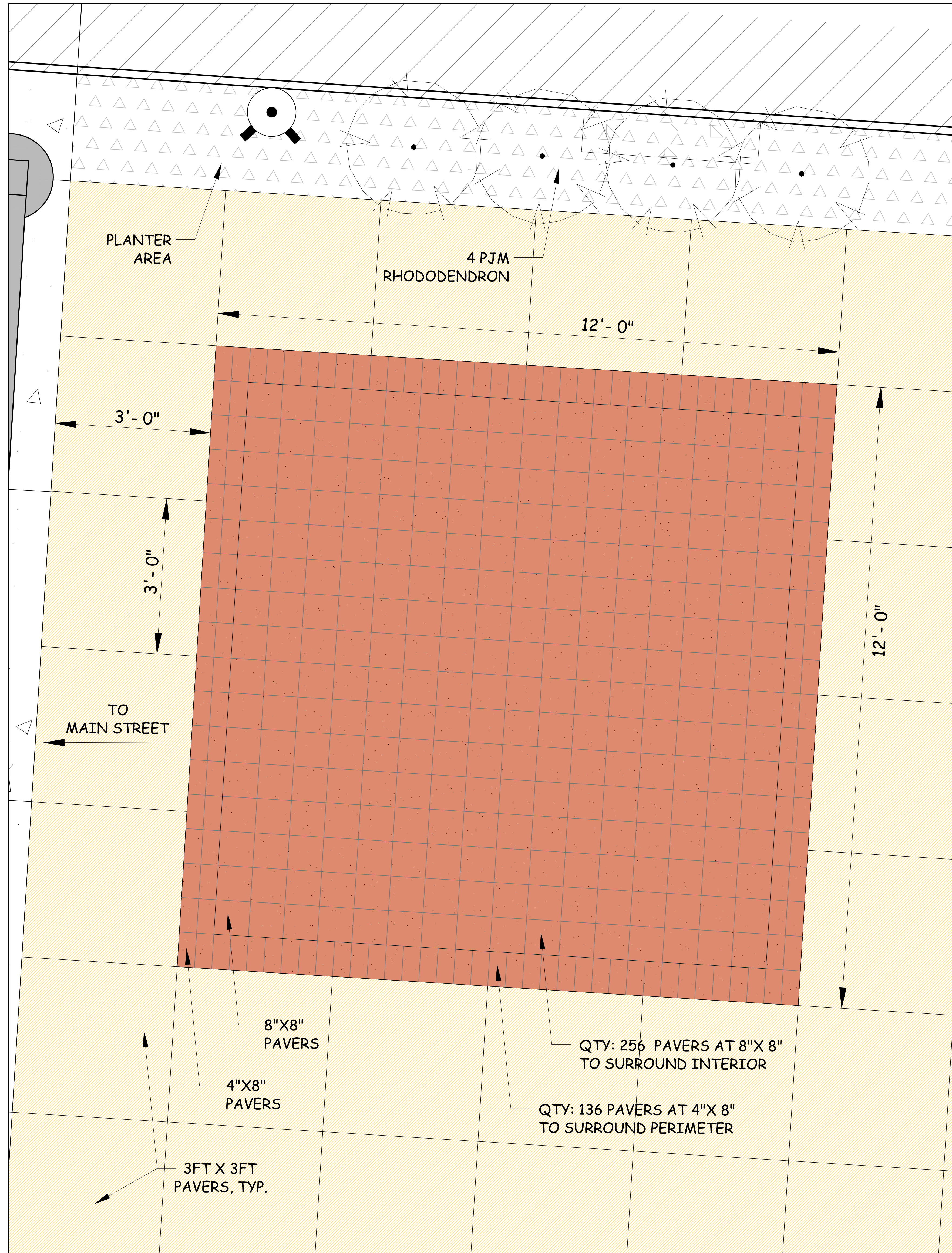

DONATION PAVER FUNDRAISING

- QUANTITY OF 4" X 8" PAVERS: 136 PAVERS X \$250 PER PAVER = \$34,000
- QUANTITY OF 8" X 8" PAVERS: 256 PAVERS X \$500 PER PAVER = \$128,000
- DONATION PAVER FUNDRAISING POTENTIAL TOTAL = \$162,000

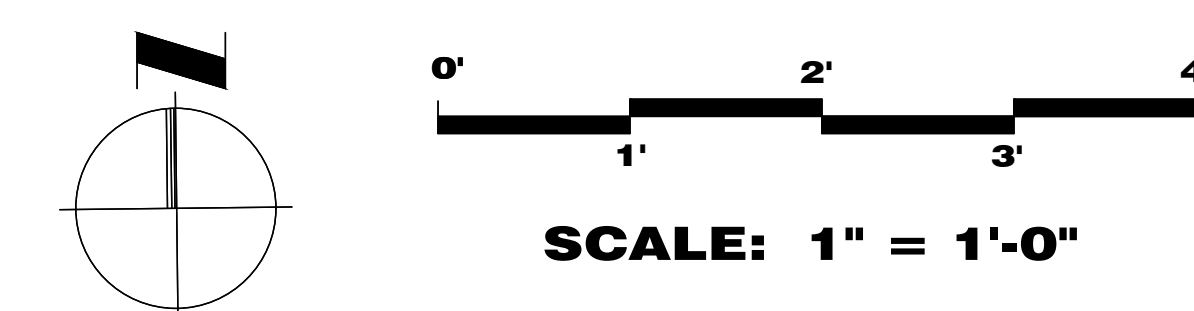

53 S Main Street, Suite 204
P.O. Box 231
Hanover NH 03755
p: 603 643 8868
www.ma-ke-arch.com



PROGRESS SET
NOT FOR CONSTRUCTION

NOT FOR CONSTRUCTION

05/16/25
PROGRESS

MARK	DATE	DESCRIPTION

Project
LEDYARD PARK

S. MAIN STREET HANOVER NH 03755 US
Project No.: 25105 | PA 2318
Sheet Title

SITE DETAILS

L4.0

© Copyright - Park Architecture, LLC, 2025

LANDSCAPE PLANTING SCHEDULE

QTY	BOTANICAL NAME	COMMON NAME	SIZE
9	RHODODENDRON 'PJM ELITE'	PJM RHODODENDRON	24"-30" HT, 5 GAL
4	ILEX GLABRA 'COMPACTA'	COMPACT HICKBERRY	24"-30" HT, 5 GAL
12	FOTHERGILLA GARDENII	DWARF FOTHERGILLA	24"-30" HT, 2 GAL
21	EUONYMUS FORTUNEI	GOLDEN EUONYMUS	18"-24" HT, 2 GAL
16	CLEMATIS X JACKMANII	JACKMAN CLEMATIS	12"-18" HT, 2 GAL

SHRUB PLANTING DETAIL

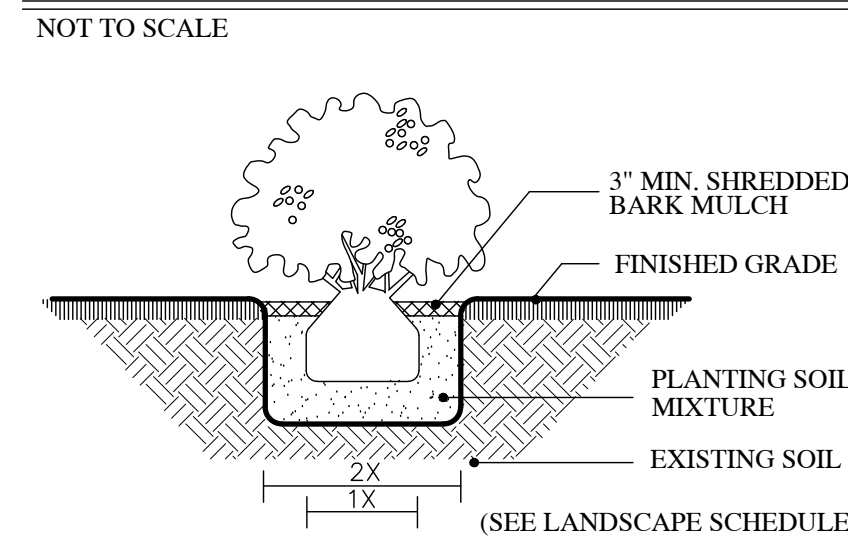

GROUNDCOVER SPACING

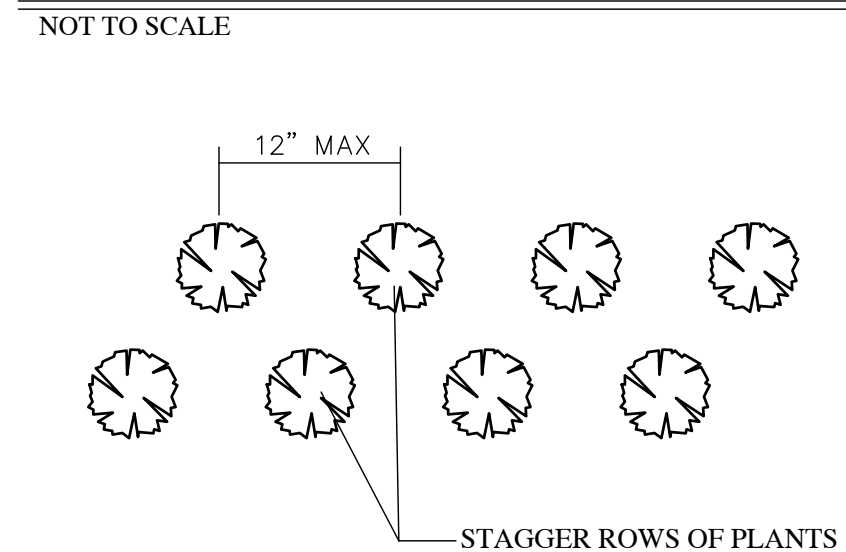

ARTIFICIAL LAWN DETAIL

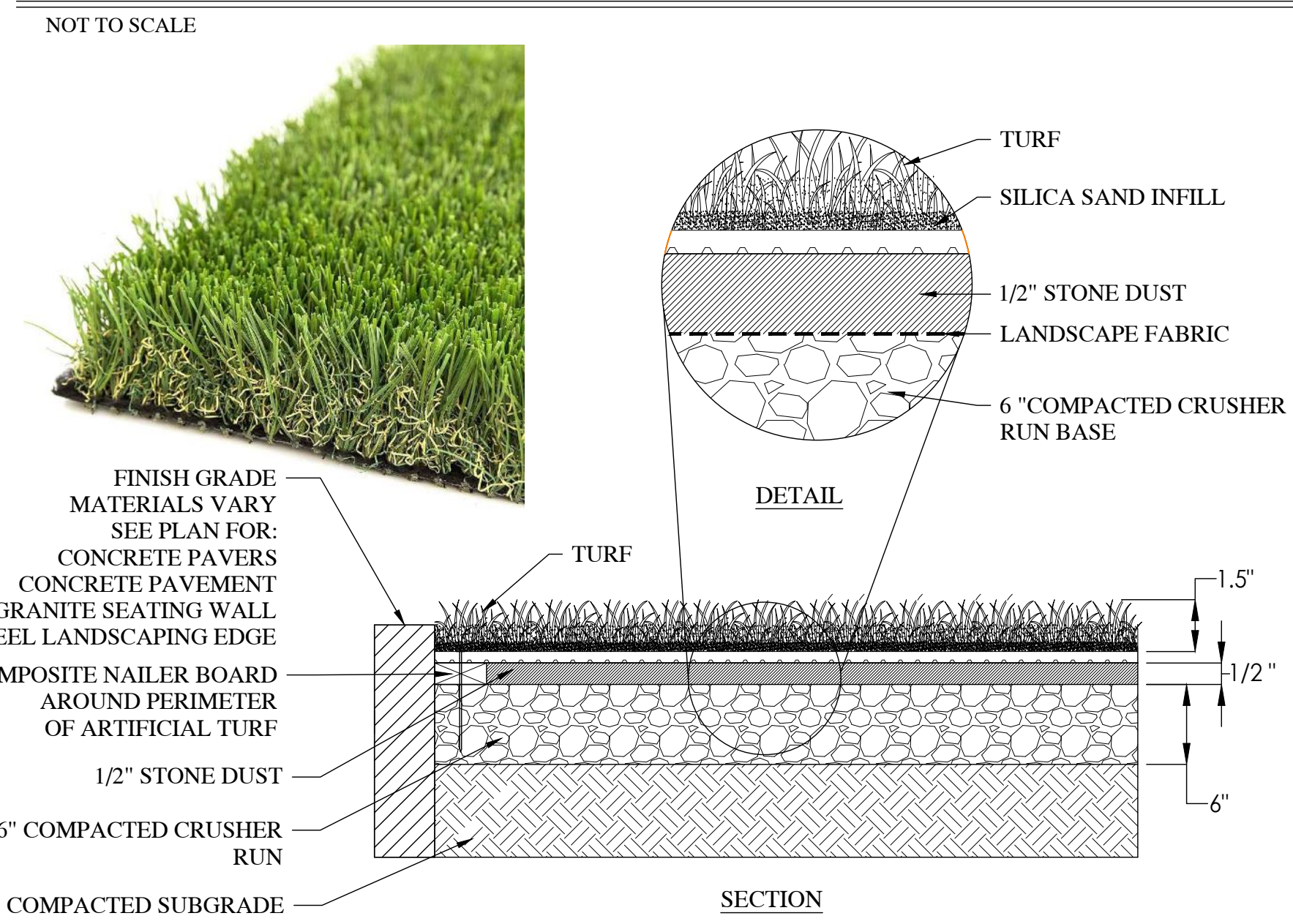

SPECIFICATIONS FOR SEALTURF™ TURF	C60		TANF3		C75		WAVE80		PET		PLAY60	
	PILE HEIGHT	FACE WEIGHT	FABRIC WIDTH	MACHINE GAUGE	FACE YARN	MIN. INFILL	PILE HEIGHT	FACE WEIGHT	FABRIC WIDTH	MACHINE GAUGE	FACE YARN	MIN. INFILL
	1.5"	60 OZ	15'	3/8"	PE-MONO	3 LBS	1.5"	73 OZ	15'	3/8"	PE-MONO	3 LBS
	1.5"	75 OZ	15'	3/8"	PE-MONO	3 LBS	2"	80 OZ	15'	3/8"	PE-MONO	3 LBS
	1.5"	55 OZ	15'	3/8"	PE-MONO	1 LBS	1.5"	50 OZ	15'	1/4"	PE-SLIT	4 LBS

- NOTES:
- ±515SF OF SELECTED SEALTURF C75
 - ARTIFICIAL LAWN SHALL BE PROVIDED BY GRASS365 OR APPROVED EQUAL. WEB: GRASS365.COM TEL: (800) 490-2971
 - COMPOSITE NAILER BOARD SHALL BE USED AROUND ENTRIE PERIMETER OF ARTIFICIAL TURF.
 - INSTALLATION TO BE COMPLETED IN ACCORDANCE WITH MANUFACTURER'S SPECIFICATIONS.
 - CONTRACTOR TO PROVIDE SHOP DRAWING TO LANDSCAPE ARCHITECT FOR APPROVAL PRIOR TO MATERIALS ORDERING AND INSTALLATION.

BOLLARD OPTION 1

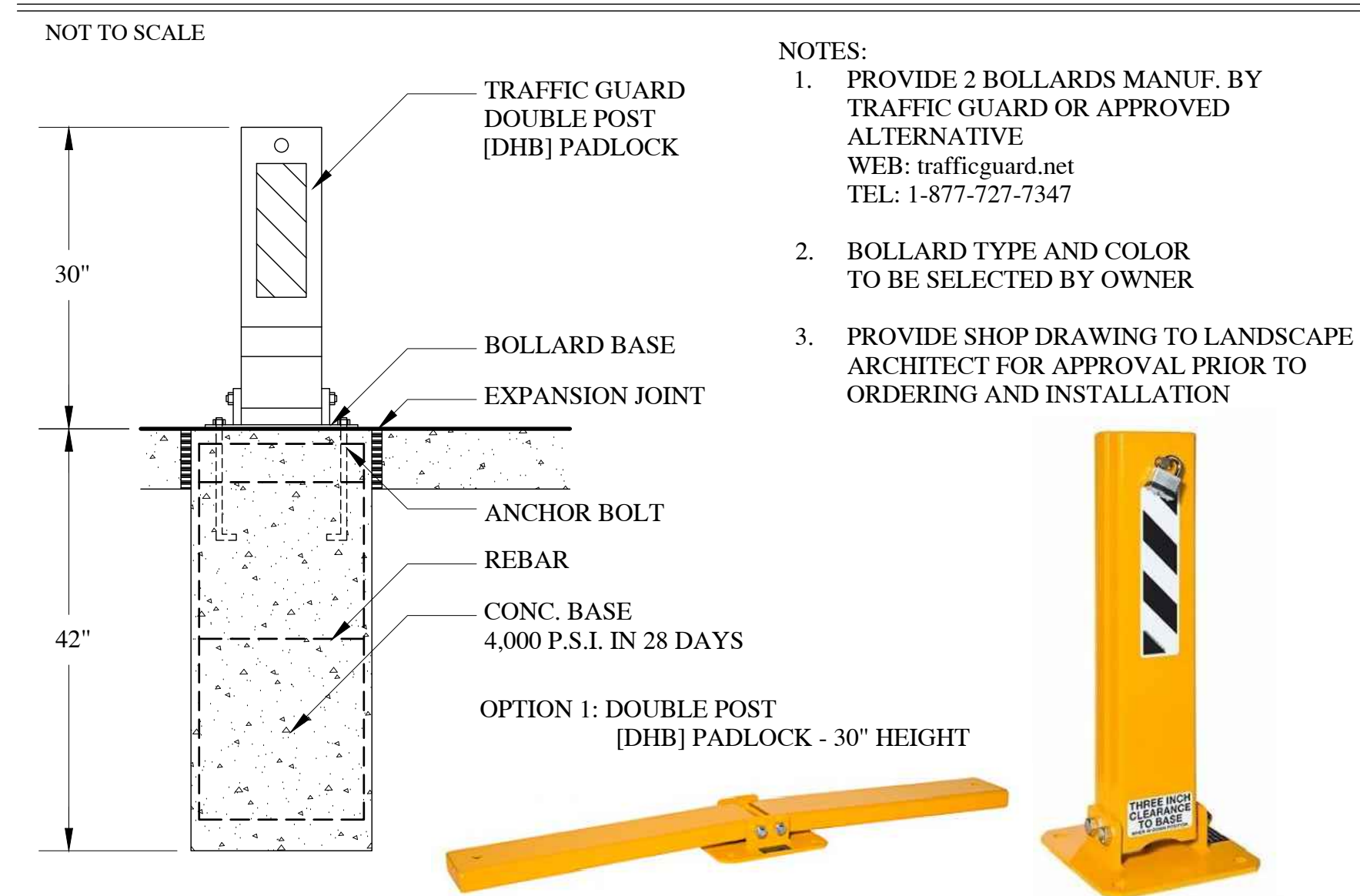

- NOTES:
- PROVIDE 2 BOLLARDS MANUF. BY TRAFFIC GUARD OR APPROVED ALTERNATIVE. WEB: trafficguard.net TEL: 1-877-727-7347
 - BOLLARD TYPE AND COLOR TO BE SELECTED BY OWNER
 - PROVIDE SHOP DRAWING TO LANDSCAPE ARCHITECT FOR APPROVAL PRIOR TO ORDERING AND INSTALLATION

STEEL LANDSCAPE EDGING

NOT TO SCALE

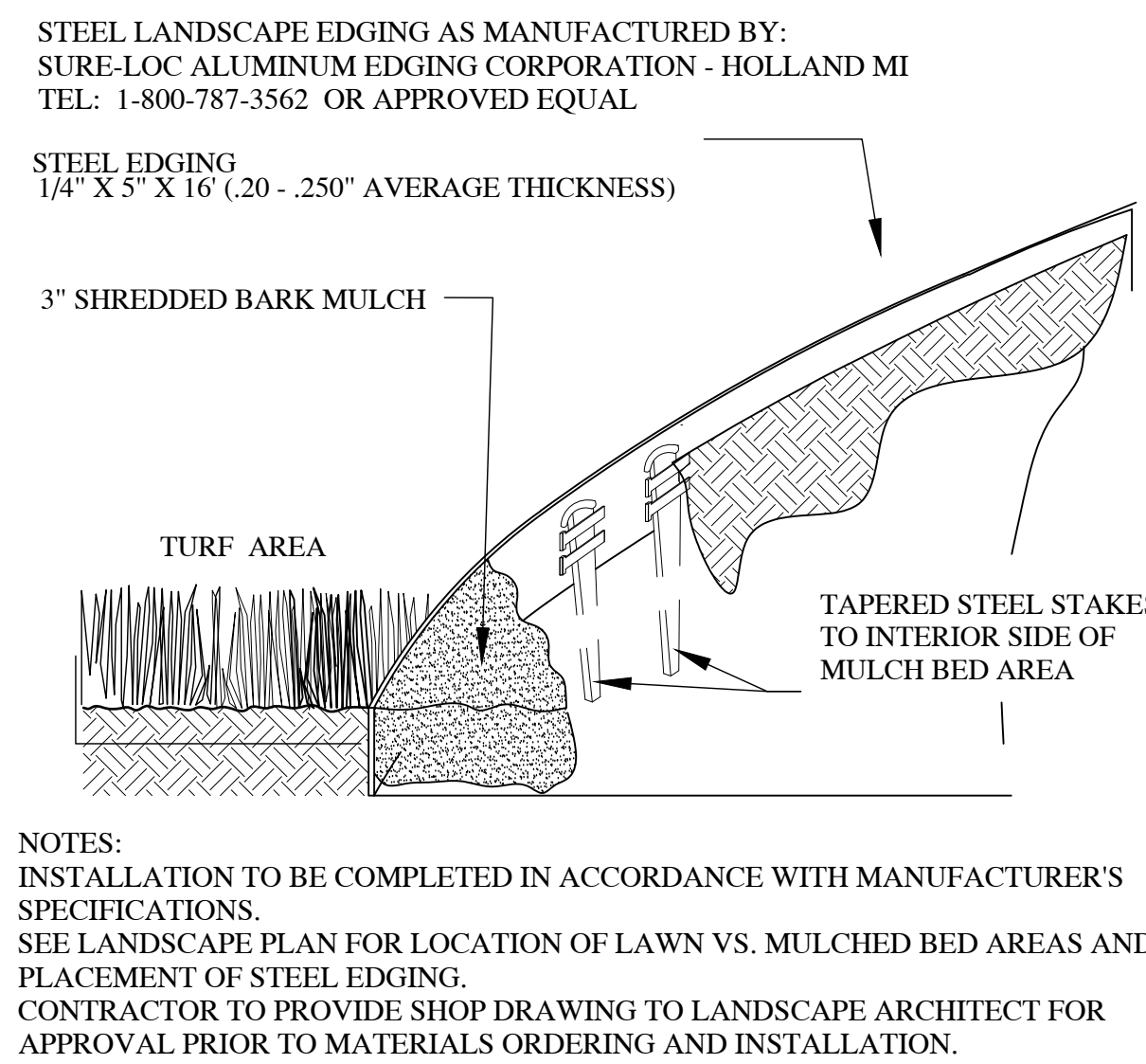

- NOTES:
- INSTALLATION TO BE COMPLETED IN ACCORDANCE WITH MANUFACTURER'S SPECIFICATIONS. SEE LANDSCAPE PLAN FOR LOCATION OF LAWN VS. MULCHED BED AREAS AND PLACEMENT OF STEEL EDGING. CONTRACTOR TO PROVIDE SHOP DRAWING TO LANDSCAPE ARCHITECT FOR APPROVAL PRIOR TO MATERIALS ORDERING AND INSTALLATION.

GRANITE SEATING WALL

NOT TO SCALE

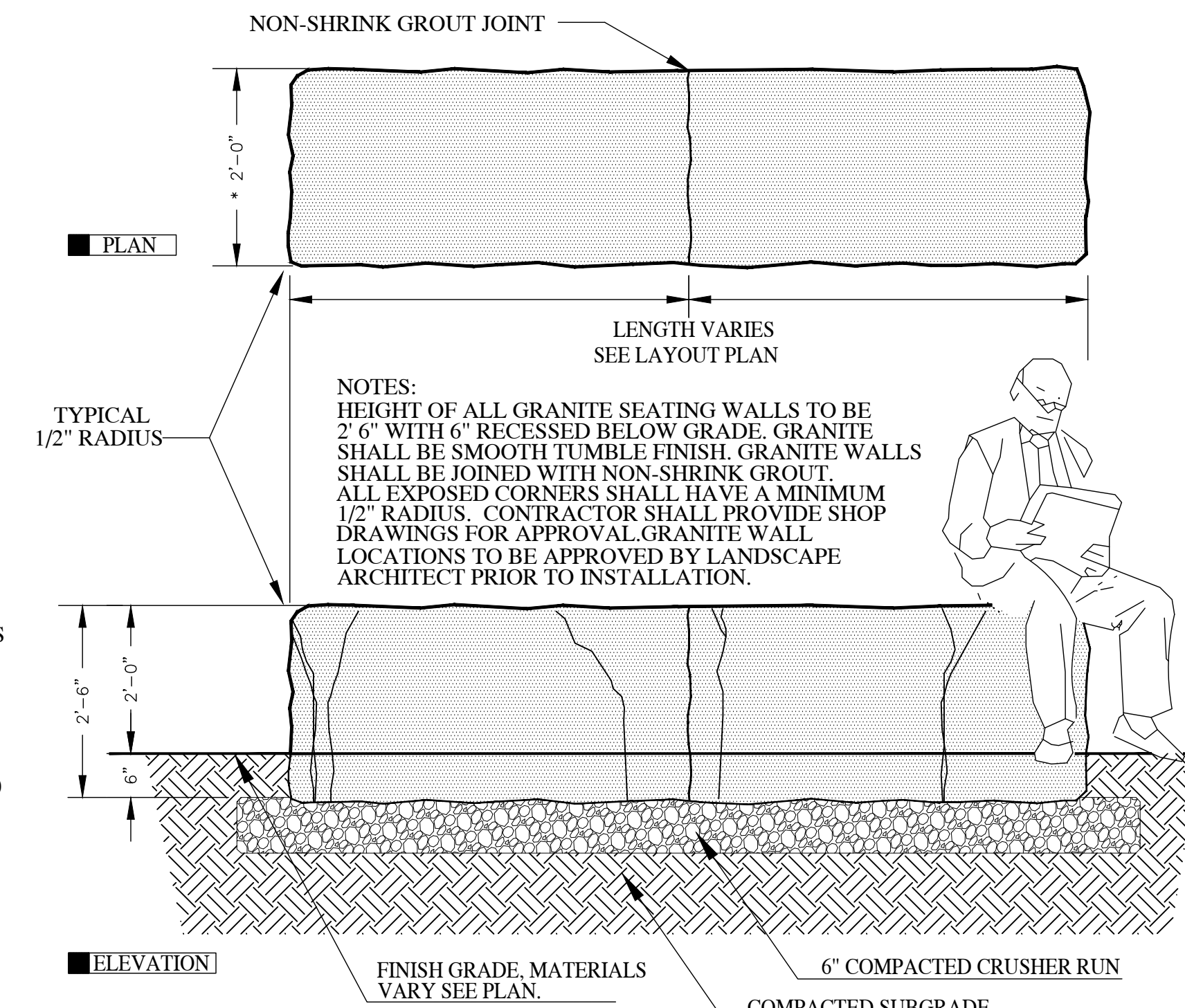
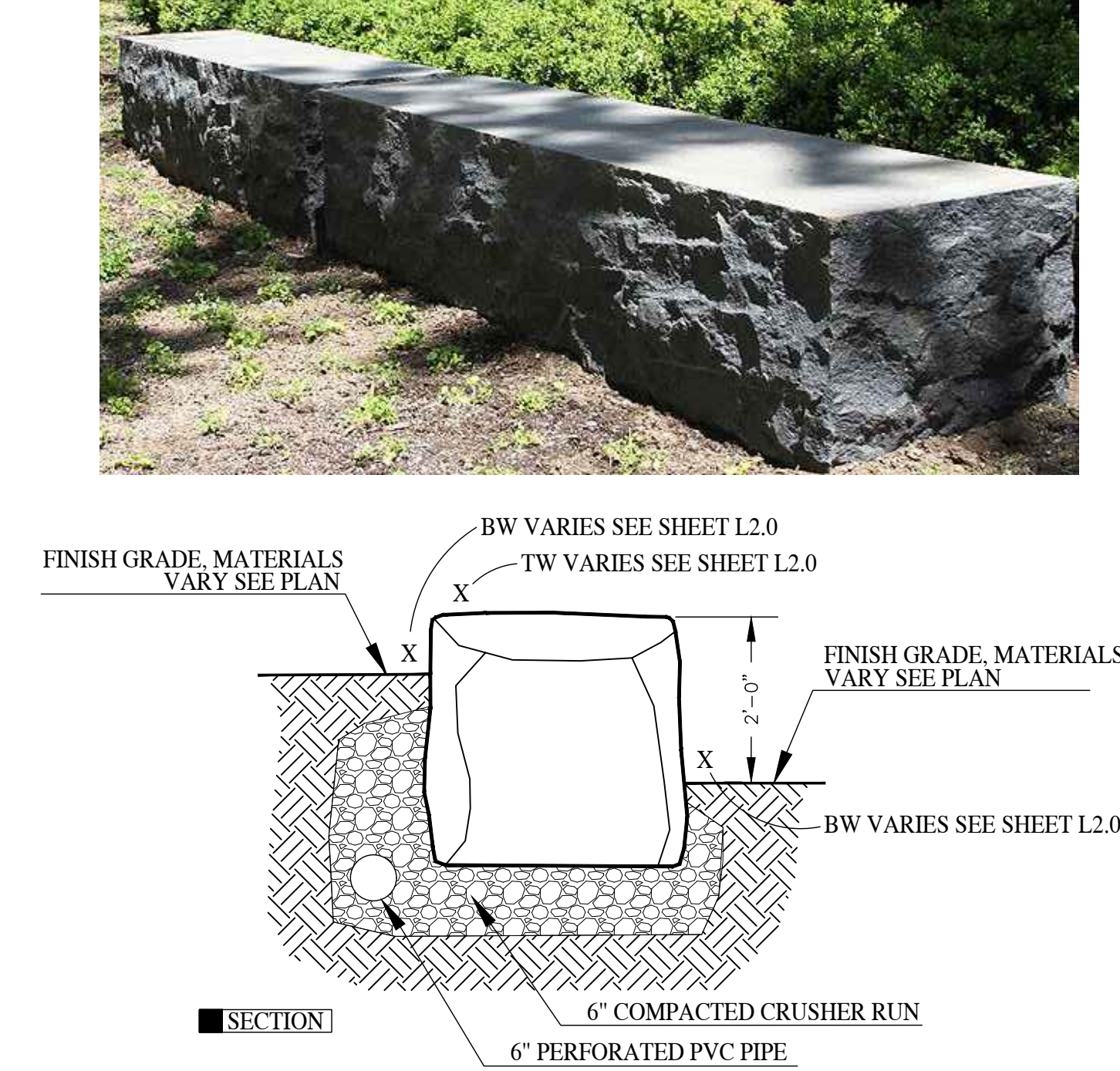

- NOTES:
- HEIGHT OF ALL GRANITE SEATING WALLS TO BE 2' 6" WITH 6" RECESSED BELOW GRADE. GRANITE SHALL BE SMOOTH TUMBLE FINISH. GRANITE WALLS SHALL BE JOINED WITH NON-SHRINK GROUT. ALL EXPOSED CORNERS SHALL HAVE A MINIMUM 1/2" RADIUS. CONTRACTOR SHALL PROVIDE SHOP DRAWINGS FOR APPROVAL. GRANITE WALL LOCATIONS TO BE APPROVED BY LANDSCAPE ARCHITECT PRIOR TO INSTALLATION.

MOUNTABLE GRANITE CURB

NOT TO SCALE

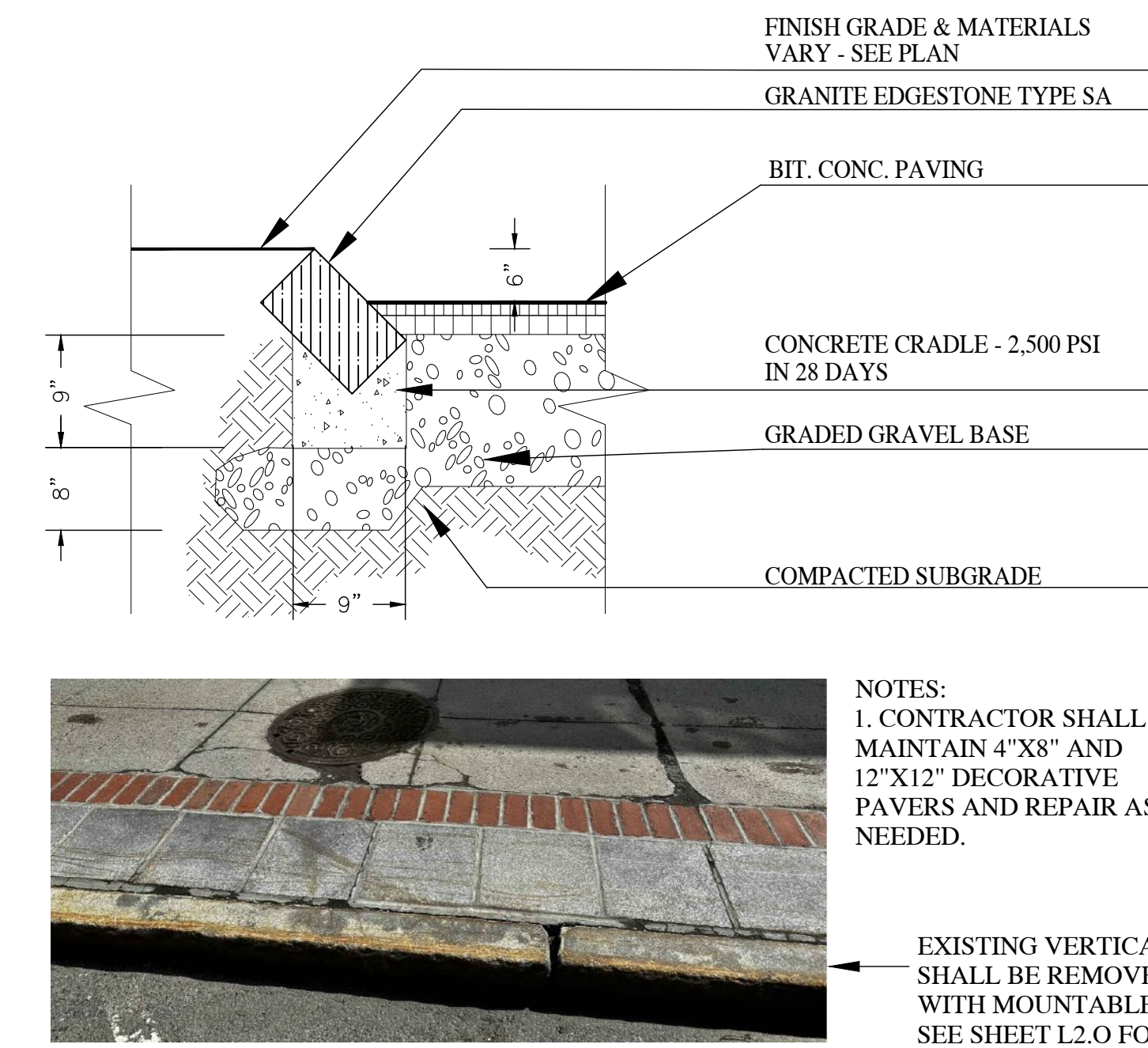

- NOTES:
- CONTRACTOR SHALL MAINTAIN 4"X8" AND 12"X12" DECORATIVE PAVERS AND REPAIR AS NEEDED.
- EXISTING VERTICAL GRANITE CURB SHALL BE REMOVED AND REPLACED WITH MOUNTABLE GRANITE CURB. SEE SHEET L2.0 FOR LOCATION.

PEACE POLE DETAIL

NOT TO SCALE

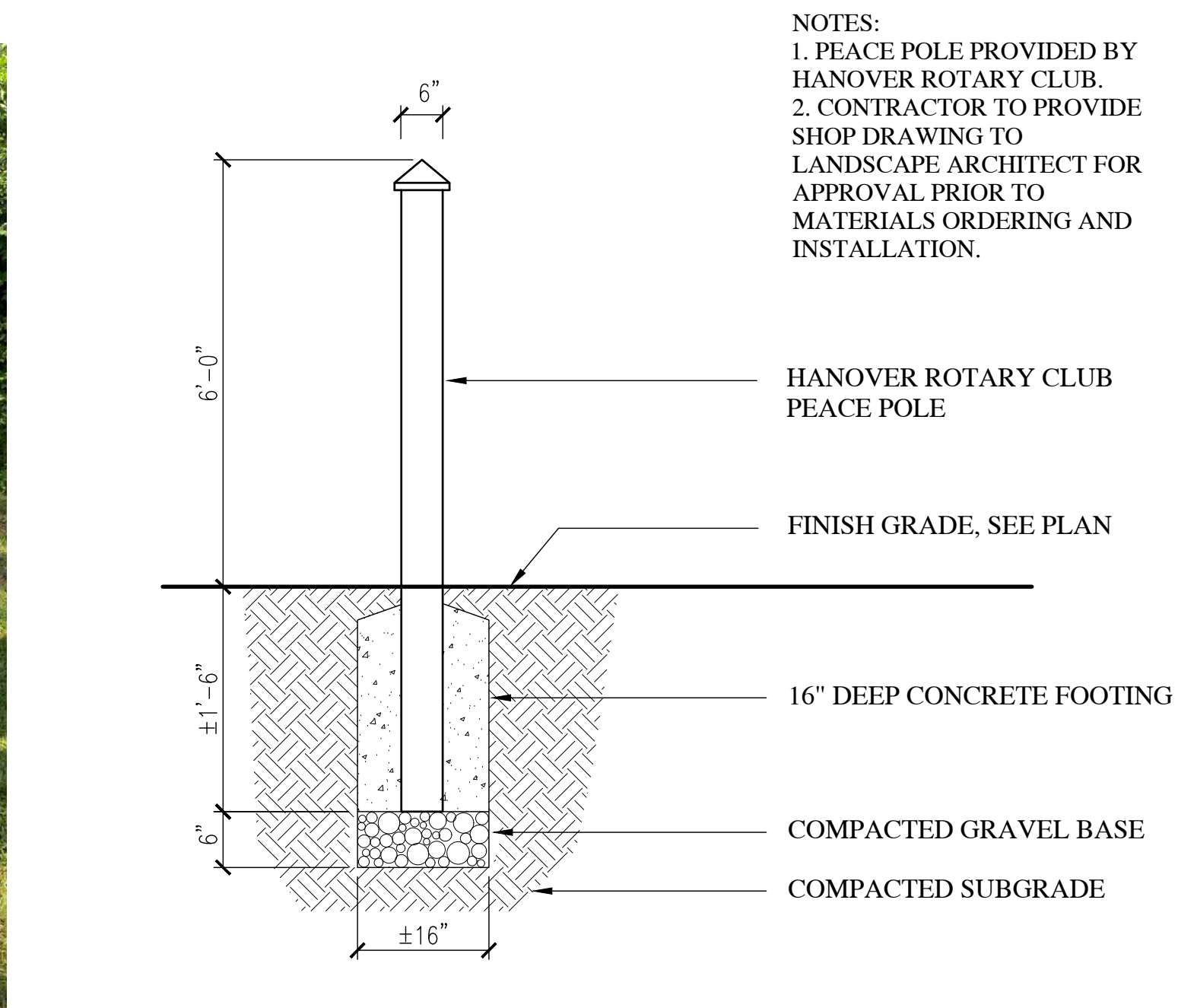

- NOTES:
- PEACE POLE PROVIDED BY HANOVER ROTARY CLUB.
 - CONTRACTOR TO PROVIDE SHOP DRAWING TO LANDSCAPE ARCHITECT FOR APPROVAL PRIOR TO MATERIALS ORDERING AND INSTALLATION.

ASPHALT DETAIL

NOT TO SCALE

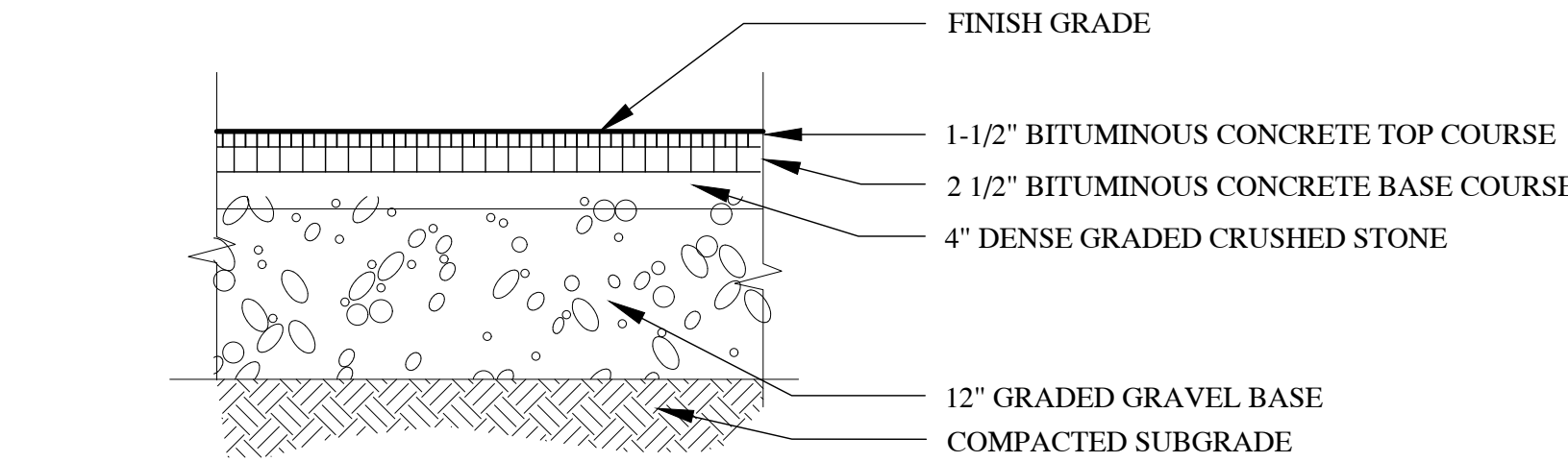

FRP TRENCH DRAIN DETAIL

NOT TO SCALE

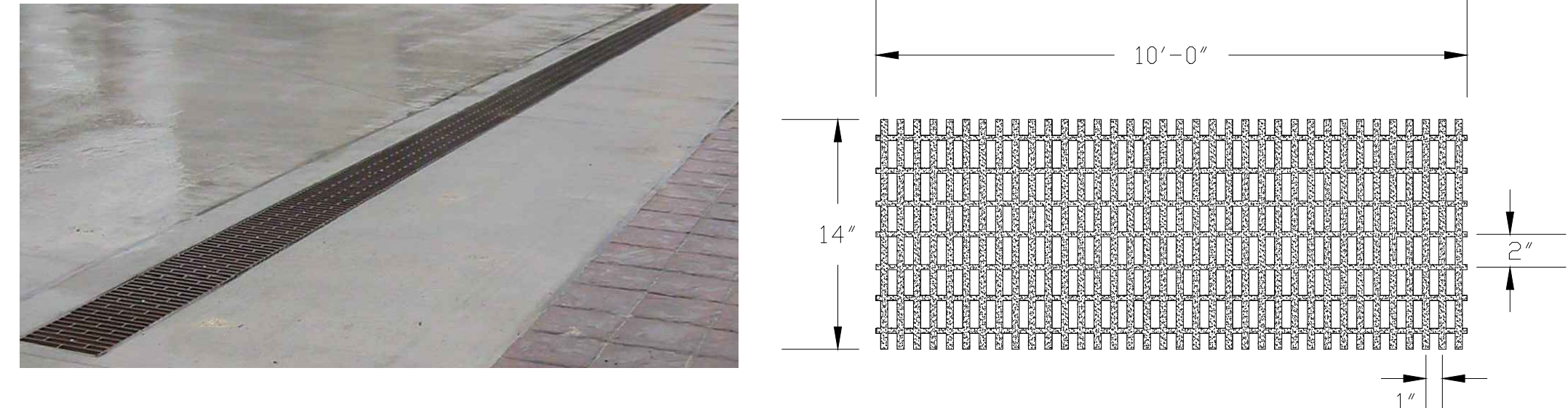

- NOTES:
- DRAIN PROVIDED BY ABT DRAINS OR APPROVED EQUAL.
 - CONTRACTOR TO PROVIDE SHOP DRAWING TO LANDSCAPE ARCHITECT FOR APPROVAL PRIOR TO MATERIALS ORDERING AND INSTALLATION.

PLAN VIEW
1 1/2" MOLDED HIGH LOAD CAPACITY FIBER- REINFORCED POLYMER (FRP) GRATING

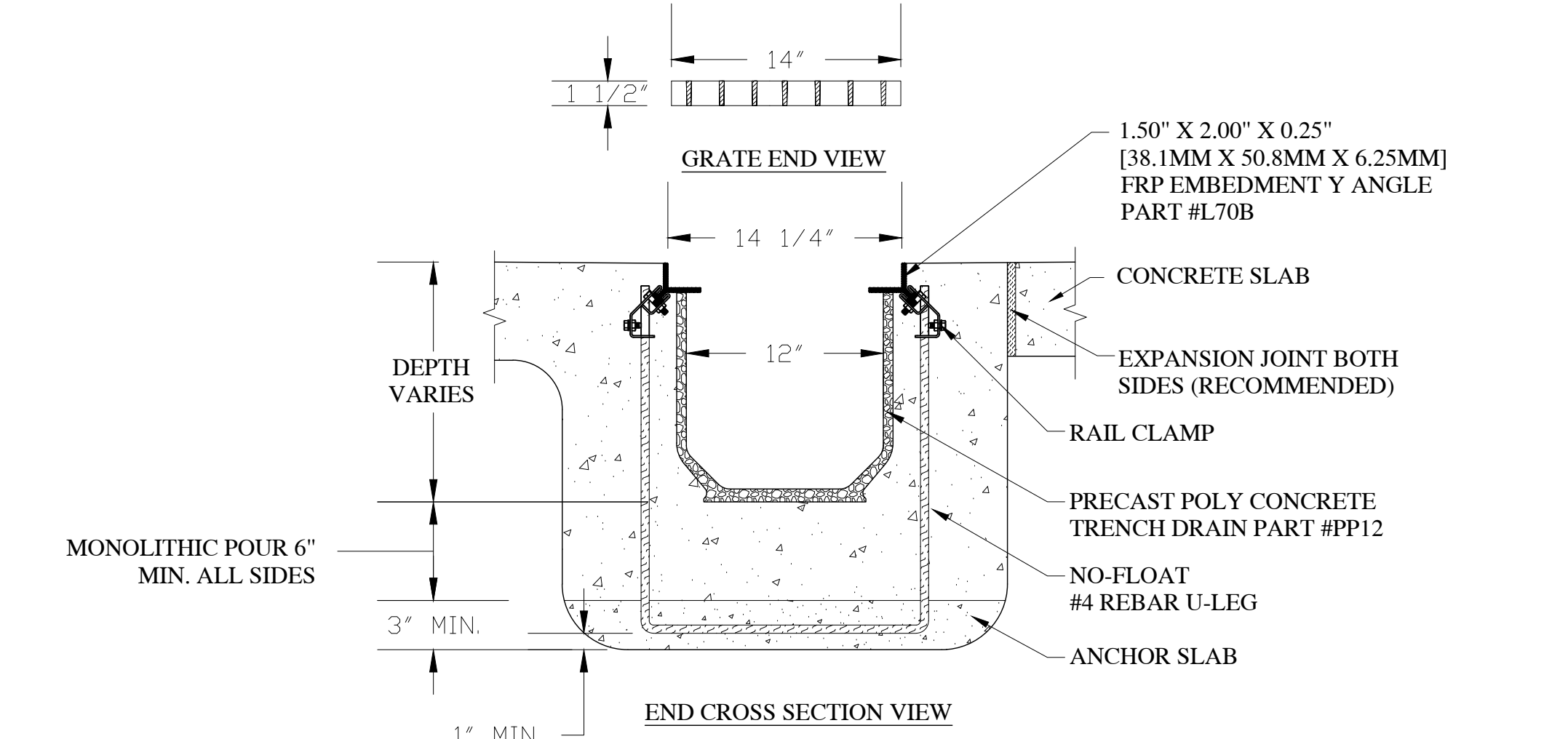

BOLLARD OPTION 2

NOT TO SCALE

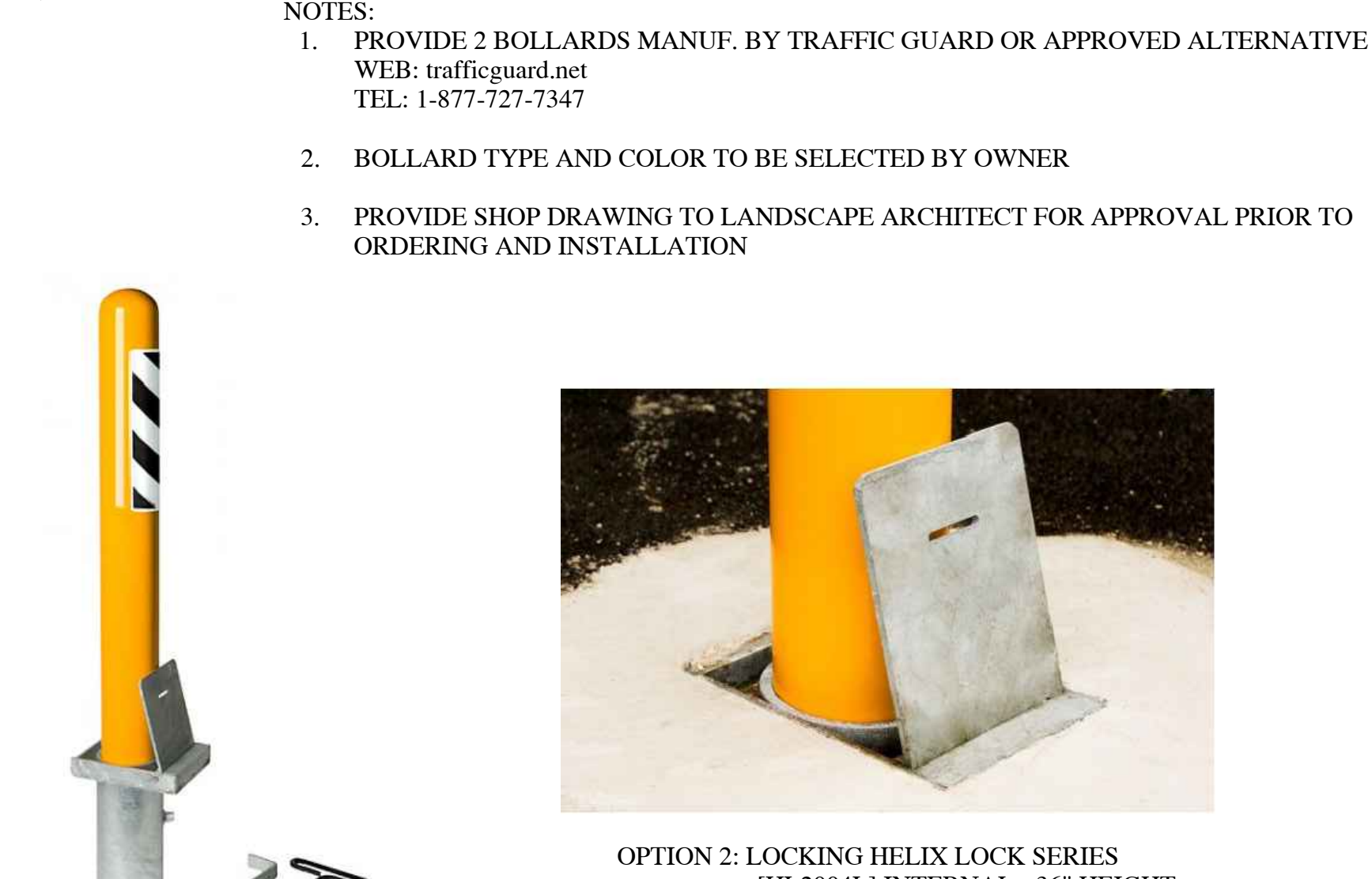

- NOTES:
- PROVIDE 2 BOLLARDS MANUF. BY TRAFFIC GUARD OR APPROVED ALTERNATIVE. WEB: trafficguard.net TEL: 1-877-727-7347
 - BOLLARD TYPE AND COLOR TO BE SELECTED BY OWNER
 - PROVIDE SHOP DRAWING TO LANDSCAPE ARCHITECT FOR APPROVAL PRIOR TO ORDERING AND INSTALLATION



OPTION 2: LOCKING HELIX LOCK SERIES (HL2004L) INTERNAL - 36" HEIGHT

(SLP) STRING LIGHT POLE (FOR SEASONAL USE ONLY)
NOT TO SCALE

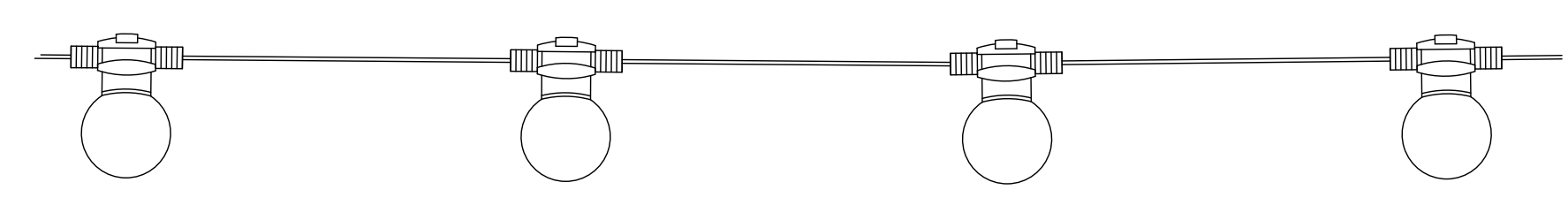
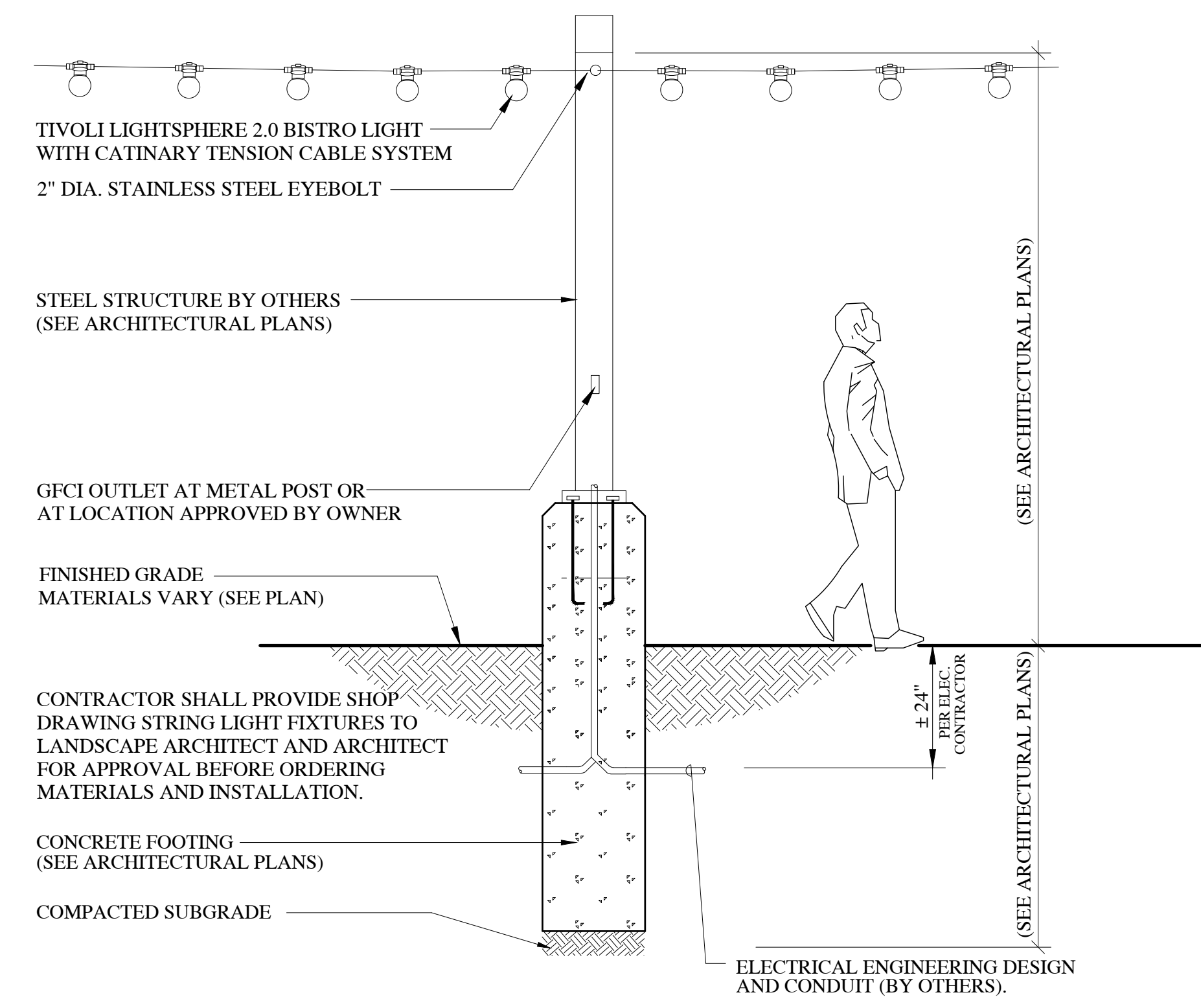

STRING LIGHTING / MAXIMUM RUN LENGTH STANDARDS

LED TYPE	6" ON CENTER	12" ON CENTER	18" ON CENTER	24" ON CENTER
STANDARD	130 FT	180 FT	230 FT	250 FT
HIGH OUTPUT	80 FT	110 FT	130 FT	150 FT
VERY HIGH OUTPUT	30 FT	55 FT	70 FT	80 FT

- Product Features**
- Tivoli's next evolution of Litesphere delivers a robust specification-grade strand with factory molded standard spacing for consistent quality from start to finish
 - Litesphere 2.0 design provides optional suspended mounting or a twist-off cap for surface applications
 - 12V DC Low voltage system for long runs
 - IP67
 - cULus
 - 3 Year warranty
- NOTES:**
- SELECTION: HIGH OUTPUT AT 24" OC SPACING
 - MAXIMUM RUN: 150 FT
 - PROVIDE 2 RUNS AS FOLLOWS:
RUN 1: ± 105 FT (SEE PLAN)
RUN 2: ± 100 FT (SEE PLAN)
 - LUMENS: 2,700
 - COLOR: BLACK
 - BULB SPACING: 24 INCHES
 - ELECTRICAL PANEL AND ELECTRICAL ENGINEERING DESIGN BY OTHERS
 - CONTRACTOR SHALL PROVIDE SHOP DRAWINGS FOR APPROVAL PRIOR TO ORDERING AND INSTALLATION

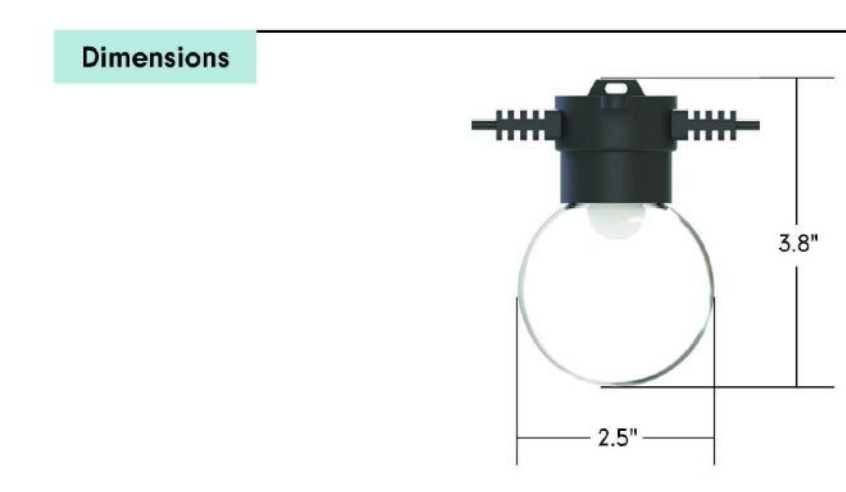

12V | Litesphere™ 2.0

System Configuration Example

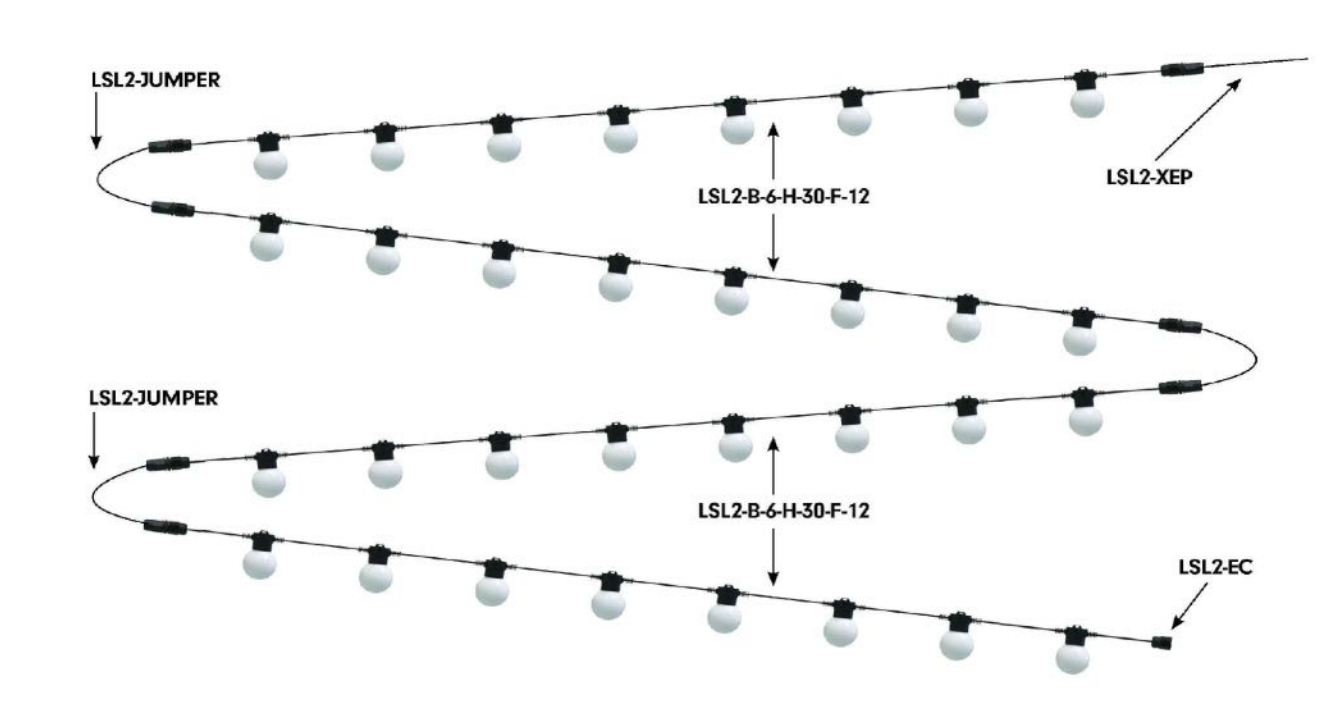

Strand Order Guide

Note: For suspension application, a catenary cable is required for proper installation. Please contact Tivoli for recommendations on unique mounting applications.

Product	Wire	Spacing	LED Type	LED Color	Globe	Voltage
LSL2	B Black	24" OC	V Very High Output	27 2700K	C Clear	12 12V DC
Litesphere 2.0	W White	12" OC	H High Output	27 2700K	F Frosted	
		18" OC	S Standard Output	30 3000K	O Opal	
		24" OC		35 3500K		
		36" OC		40 4000K		
		48" OC		50 5000K*		
				AM Amber*		
				BB Royal Blue*		
				BD Red*		
				GN Green*		
				YL Yellow*		

*Available in VHO LED only

SEATING TABLE AND CHAIRS
NOT TO SCALE

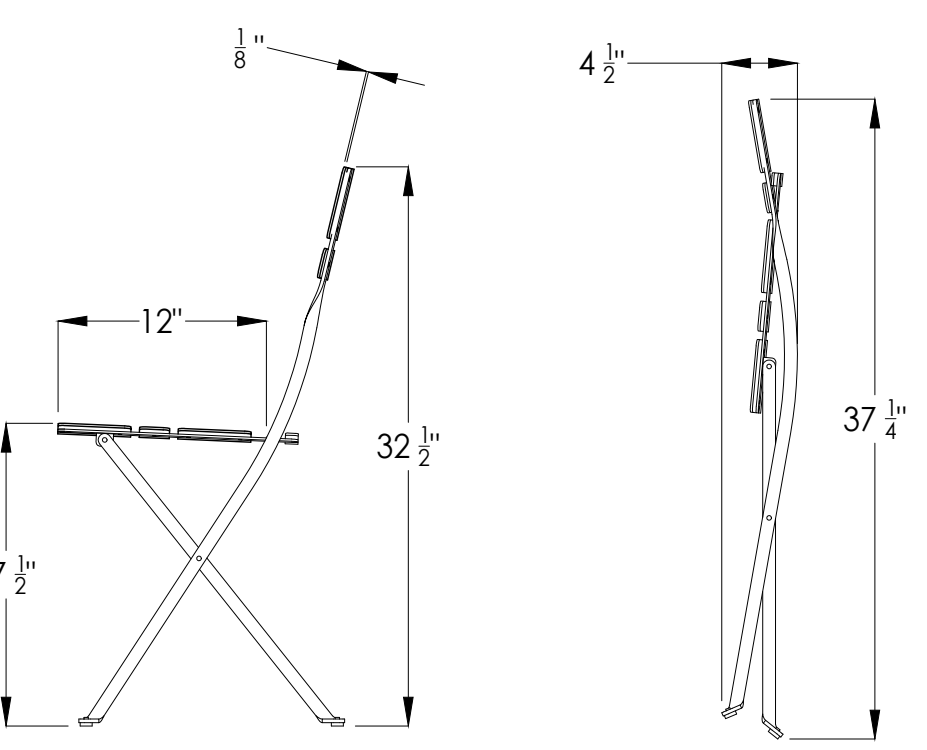
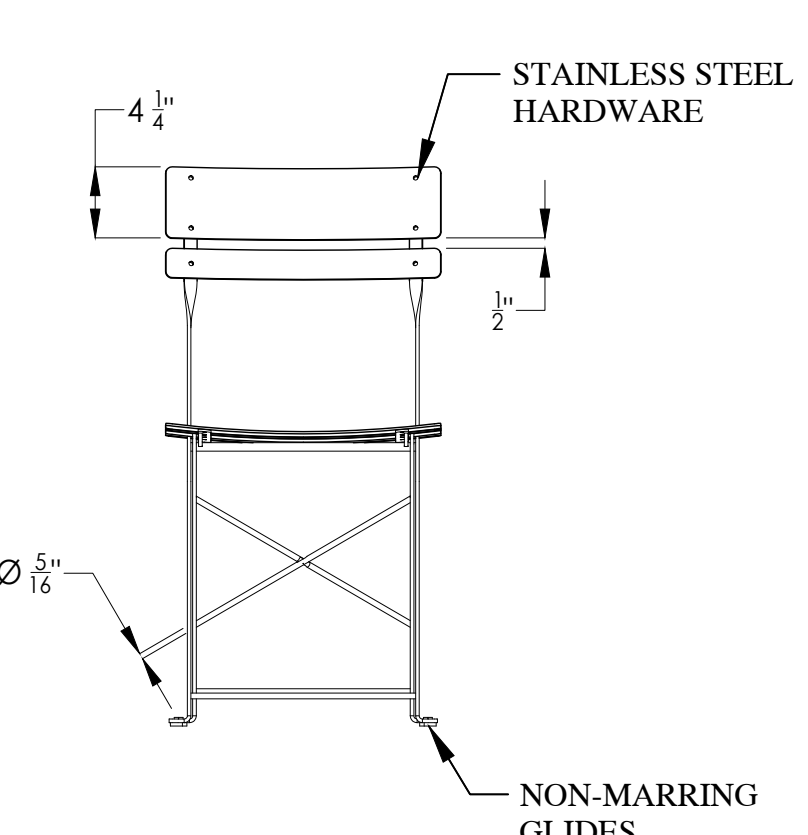
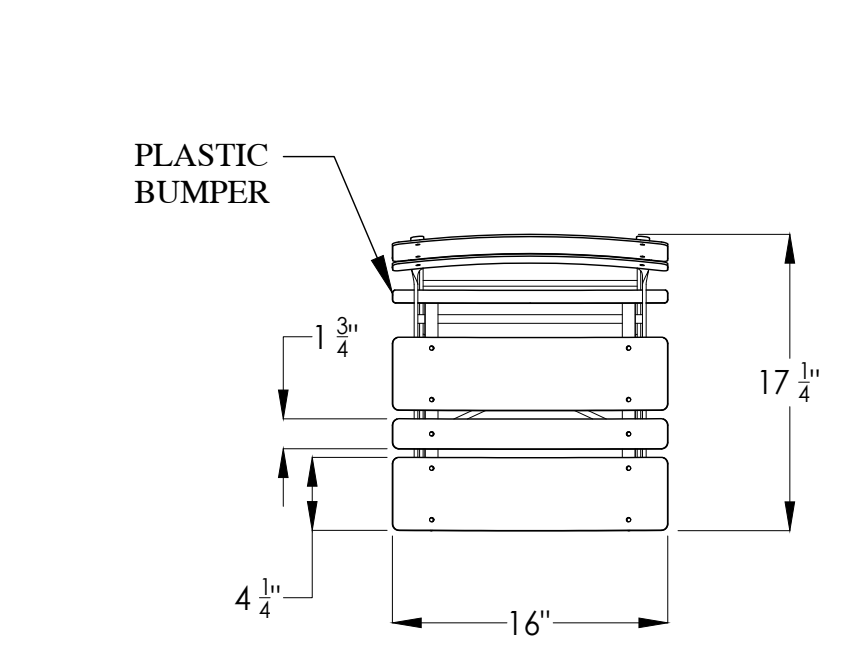

- NOTES:**
- CHAIRS AND TABLE SHALL BE PROVIDED BY LANDSCAPEFORMS OR APPROVED EQUAL.
WEB: WWW.LANDSCAPEFORMS.COM
TEL: 800-521-2546
 - PRODUCT LINE: BRAVO BISTRO
 - CHAIRS SOLD AS SET OF 2
 - PRODUCT FINISH POWDERCOAT COLOR: CADMIUM OR SELECTED BY OWNER.
 - CONTRACTOR TO PROVIDE SHOP DRAWING TO LANDSCAPE ARCHITECT FOR APPROVAL PRIOR TO MATERIALS ORDERING AND INSTALLATION.

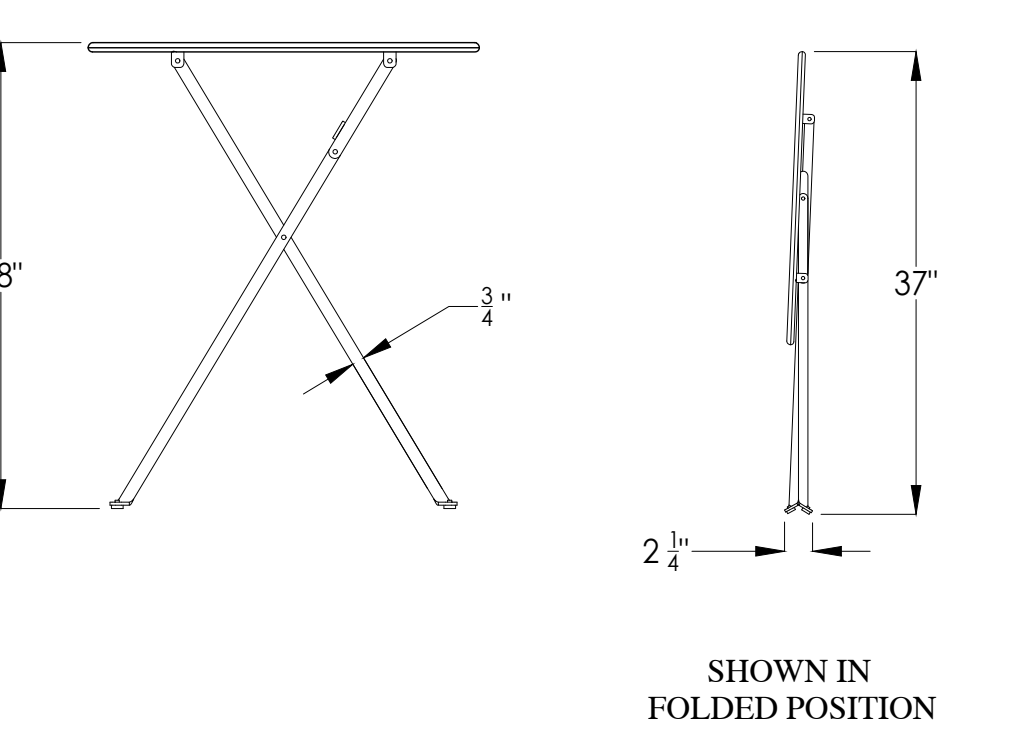
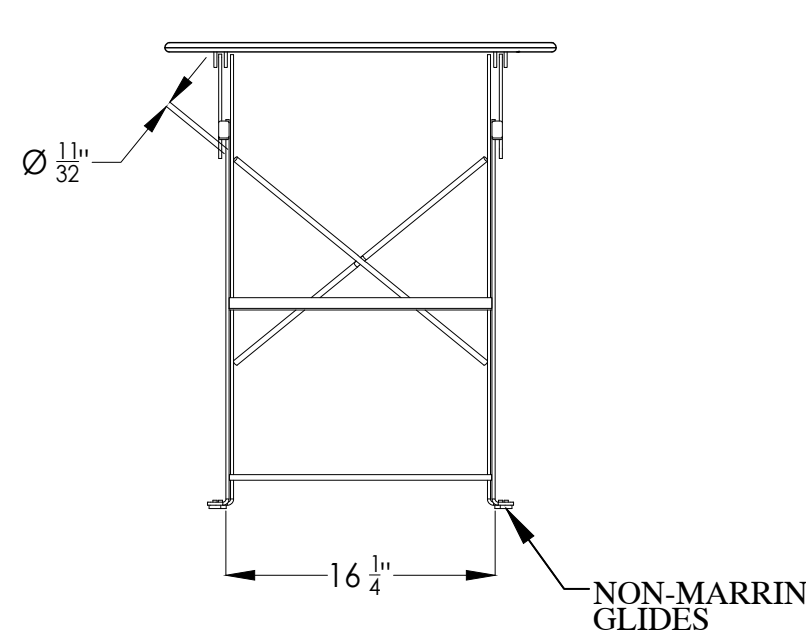
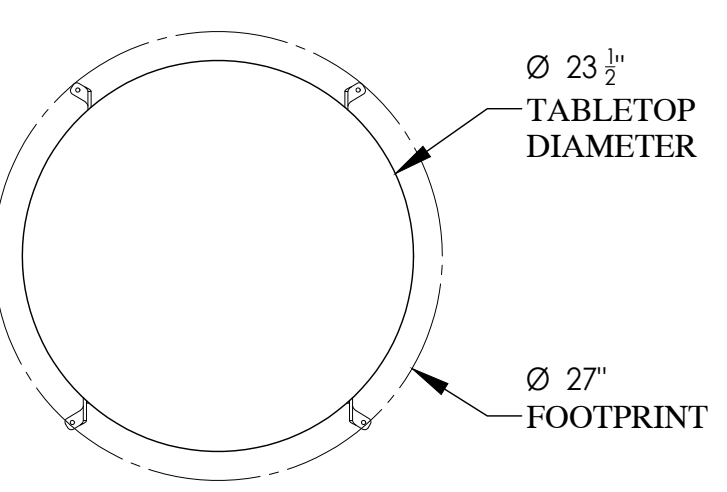

DONATION PAVERS
NOT TO SCALE

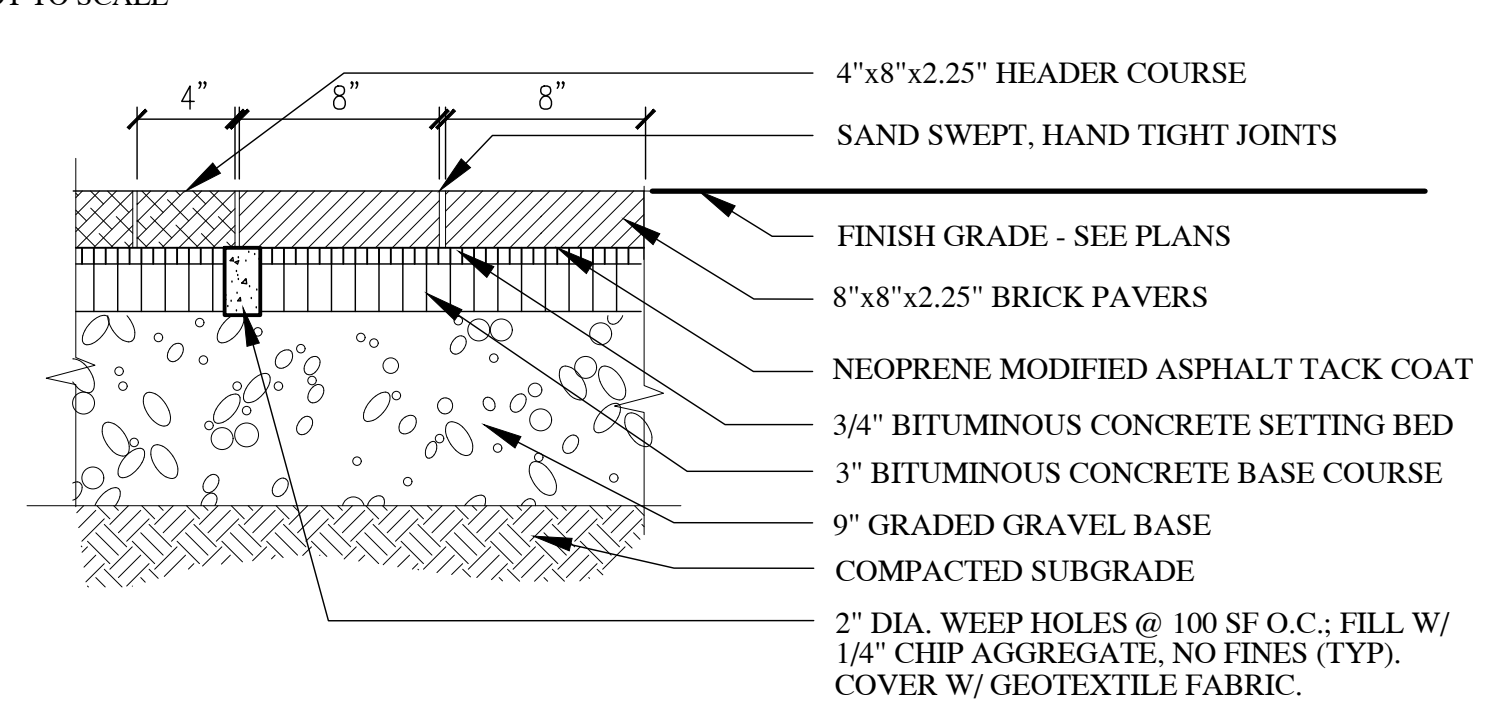

- NOTES:**
- INSTALL HEADER COURSE AROUND PERIMETER. SEE SHEET L4.0
 - PROTECT PAVER SURFACE WITH URETHANE SCUFF PAD DURING COMPACTION, AND PROTECT PAVER SURFACE FROM ALL OTHER CONSTRUCTION ACTIVITIES.

CONCRETE PAVING / JOINT TREATMENT DETAIL
SCALE: NTS

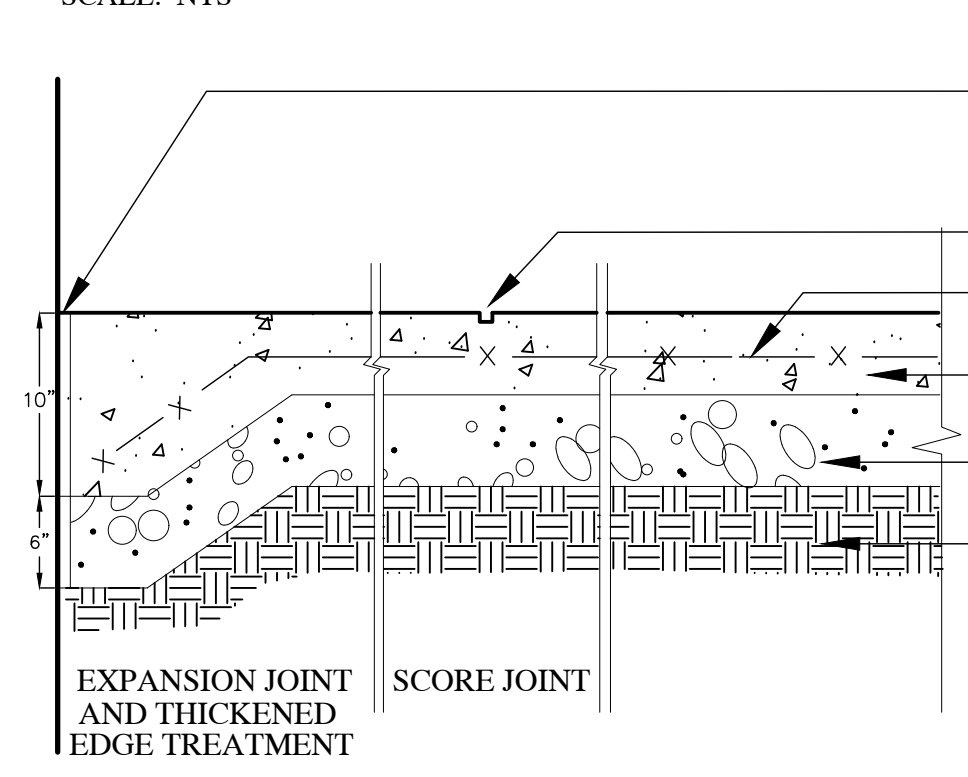

- EXPANSION JOINT - 1/2" WIDE NON-BITUMINOUS, NON-EXTRUDING PRE-FORMED FILLER FULL DEPTH OF JOINT. E.J. TO BE TOPPED WITH POLYURETHANE SEALANT 1/2" DEEP.**
- SCORE JOINT AS SHOWN ON PLANS
6" X 6" #10 W.W.M. IN CENTER OF SLAB
- CONCRETE SLAB 6" THICK WITH THICKENED EDGE @ ALL CHANGES OF MATERIALS.
6" GRADED GRAVEL BASE MATERIAL
- COMPACTED SUBGRADE
- NOTE 1: PROVIDE EXPANSION JOINTS AS SHOWN ON THE DRAWINGS, WHEREVER PAVING MEETS VERTICAL OR HORIZONTAL MASONRY SURFACES, AND NOT MORE THAN 24" O.C. IN ANY DIRECTION.
- NOTE 2: CONCRETE 4000 P.S.I. IN 28 DAYS

3FT X 3FT CONCRETE PATIO PAVERS
NOT TO SCALE

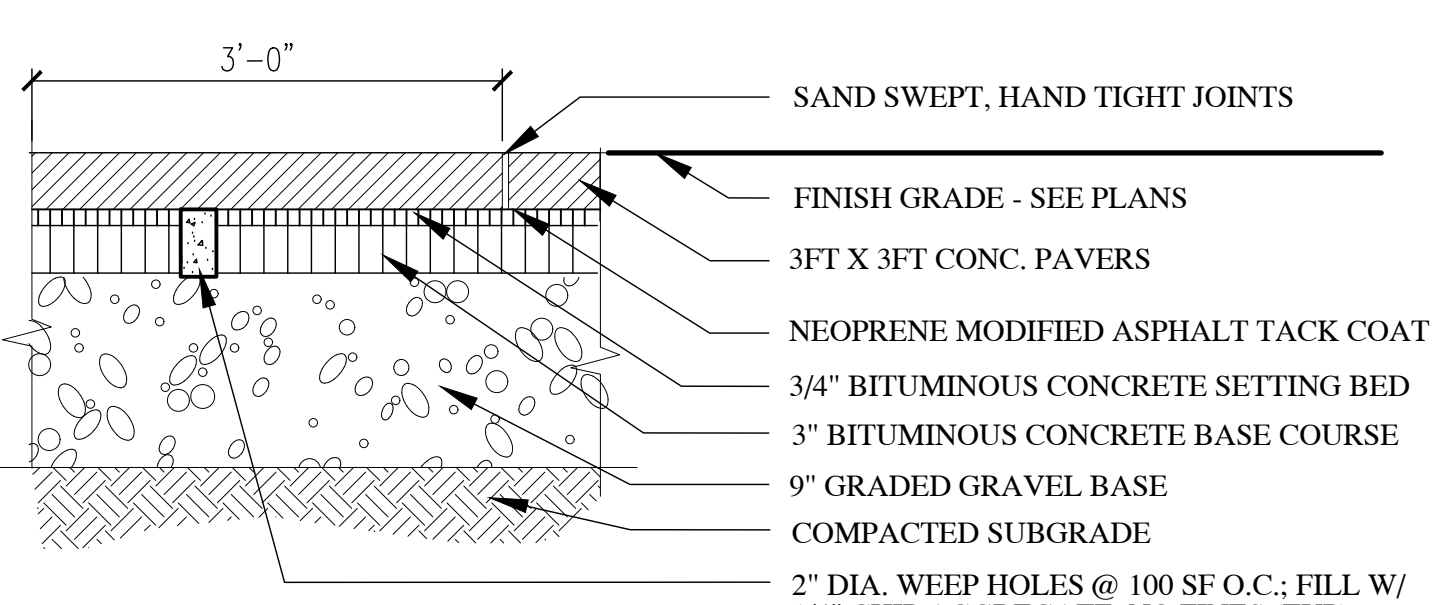
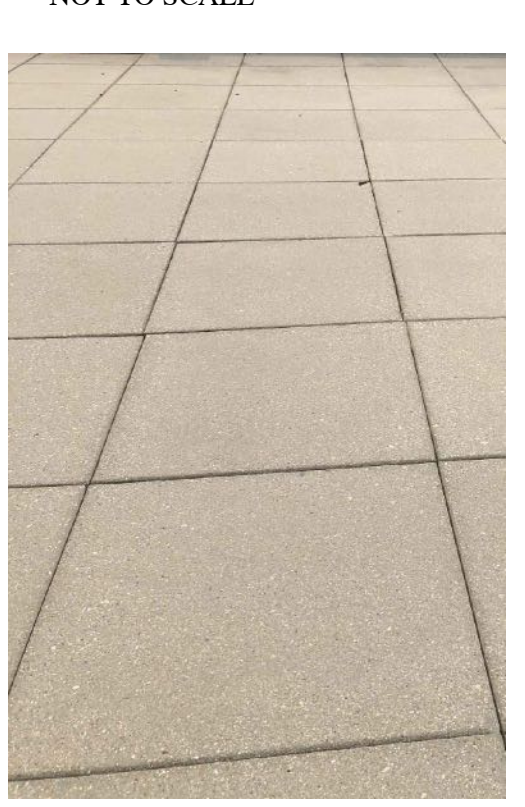

- NOTES:**
- PROTECT PAVER SURFACE WITH URETHANE SCUFF PAD DURING COMPACTION, AND PROTECT PAVER SURFACE FROM ALL OTHER CONSTRUCTION ACTIVITIES.

Issued

NOT FOR CONSTRUCTION

05/16/25

PROGRESS

MARK DATE DESCRIPTION

MARK	DATE	DESCRIPTION

Project

LEDYARD PARK

S. MAIN STREET HANOVER NH 03755 US

Project No.: 25105 | PA 2318
Sheet Title

SITE DETAILS

Town of Hanover Schedule of Rates and Fees for FY2026 (July 1, 2025-June 30, 2026)

FIRE DEPARTMENT					
<u>Type of Fee</u>	<u>Adopted FY2021-22</u>	<u>Adopted FY2022-23</u>	<u>Adopted FY2023-24</u>	<u>Adopted FY2024-25</u>	<u>Proposed FY2025-26</u>
Fire Safety Crowd Control - Manpower	Cost +50%	Cost +50%	Cost +50%	Cost +50%	Cost +50%
Fire Safety Crowd Control - Manned Apparatus	\$210.00/hour	\$210.00/hour	\$230.00/hour	\$230.00/hour	\$230.00/hour
False Alarm Charge - Fire Service	1st: Free	1st: Free	1st: Free	1st: Free	1st: Free
	2nd: \$110.00	2nd: \$110.00	2nd: \$120.00	2nd: \$120.00	2nd: \$120.00
	3rd: \$210.00	3rd: \$210.00	3rd: \$230.00	3rd: \$230.00	3rd: \$230.00
	4th and beyond: \$310 per response	4th and beyond: \$310 per response	4th and beyond: \$340 per response	4th and beyond: \$340 per response	4th and beyond: \$340 per response
Fire Extinguisher Training (for 1-10 students)	\$110.00	\$110.00	\$110.00	\$110.00	\$110.00
Fire Extinguisher Training (for 10 or more students)	\$15.00 per student	\$15.00 per student	\$15.00 per student	\$15.00 per student	\$15.00 per student
Fire Suppression System Review: new systems, additions, alterations	\$110 base review fee PLUS \$0.10/\$1,000 cost of construction	\$110 base review fee PLUS \$0.45/\$1,000 cost of construction	\$120 base review fee PLUS \$0.45/\$1,000 cost of construction	\$120 base review fee PLUS \$0.45/\$1,000 cost of construction	\$120 base review fee PLUS \$0.45/\$1,000 cost of construction
Fire Alarm Review: new systems, additions, alterations	\$110 base review fee PLUS \$0.10/\$1,000 cost of construction	\$110 base review fee PLUS \$0.45/\$1,000 cost of construction	\$120 base review fee PLUS \$0.45/\$1,000 cost of construction	\$120 base review fee PLUS \$0.45/\$1,000 cost of construction	\$120 base review fee PLUS \$0.45/\$1,000 cost of construction
Additional Fire Inspection Services	n/a	\$75.00/hour	\$85.00/hour	\$85.00/hour	\$85.00/hour
Rescheduling of Fire Alarms or Sprinkler Acceptance Test because of contractor/owner not ready for test	n/a	\$510.00	\$510.00	\$510.00	\$510.00
Report Copy (Flat Fee)	\$25.00	\$25.00	\$25.00	\$25.00	\$25.00

Town of Hanover Schedule of Rates and Fees for FY2026 (July 1, 2025-June 30, 2026)

<u>Type of Fee</u>	<u>Adopted</u> <u>FY2021-22</u>	<u>Adopted</u> <u>FY2022-23</u>	<u>Adopted</u> <u>FY2023-24</u>	<u>Adopted</u> <u>FY2024-25</u>	<u>Proposed</u> <u>FY2025-26</u>
AMBULANCE DIVISION					
Per Capita - Hanover	\$40.22	\$41.31	\$43.38	\$45.55	\$48.74
Per Capita - Lyme	\$40.22	\$41.31	\$43.38	\$45.55	\$48.74
Per Capita - Norwich	\$40.22	\$41.31	\$43.38	\$45.55	\$48.74
Community Contributions Adjustment to Cover Insurance Contractual Obligations for Ambulance Calls Originating in Community	Pro-Rated Share of Lost Revenues	Pro-Rated Share of Lost Revenues	Pro-Rated Share of Lost Revenues	Pro-Rated Share of Lost Revenues	Pro-Rated Share of Lost Revenues
Report Copy (Flat Fee)	\$25.00	\$25.00	\$25.00	\$25.00	\$25.00
Treatment with Transport - Basic Life Support – (plus mileage)	\$900.00	\$900.00	\$ 990.00	\$ 990.00	\$ 1,060.00
Treatment with Transport - Advanced Life Support Level 1 – (plus mileage)	\$900.00	\$900.00	\$ 990.00	\$ 990.00	\$ 1,060.00
Treatment with Transport - Advanced Life Support Level 2 – (plus mileage)	\$1,300.00	\$1,300.00	\$ 1,430.00	\$ 1,430.00	\$ 1,530.00
Treatment with Transport - Special Care Transport	\$1,300.00	\$1,300.00	\$ 1,430.00	\$ 1,430.00	\$ 1,530.00
Mileage Rate	\$20.00/mile	\$20.00/mile	\$22.00/mile	\$22.00/mile	\$23.50/mile
Treatment and Release Fee	\$150.00	\$150.00	\$165.00	\$165.00	\$175.00
Emergency Services Paramedic Intercept Charge	\$350.00	\$350.00	\$385.00	\$385.00	\$410.00
Ambulance - Special Event Standby	\$225.00/hour	\$225.00/hour	\$250.00/hour	\$250.00/hour	\$265/hour

Town of Hanover Schedule of Rates and Fees for FY2026 (July 1, 2025-June 30, 2026)

GENERAL ADMINISTRATION / OTHER

<u>Type of Fee</u>	<u>Adopted FY2021-22</u>	<u>Adopted FY2022-23</u>	<u>Adopted FY2023-24</u>	<u>Adopted FY2024-25</u>	<u>Proposed FY2025-26</u>
Processing Fee for Returned Deposit Item (NSF Checks or Checks Drawn on Closed Accounts; Rejected ACH Transactions)	\$25.00	\$25.00	\$25.00 plus all protest, bank, mailing and legal fees	\$25.00 plus all protest, bank, mailing and legal fees	\$25.00 plus all protest, bank, mailing and legal fees
Late Fee on Overdue Balances from General Service Invoices (billed through the Town's Accounting Office)	12.00% per annum interest	12.00% per annum interest	12.00% per annum interest	12.00% per annum interest	12.00% per annum interest
General Photocopying, including RSA 91-A Right-to-Know Requests single page (8.5" x 11.0")	\$.25/page	\$.25/page	\$.25/page	\$.25/page	\$.25/page
General Photocopying, including RSA 91-A Right-to-Know Requests – single page (8.5" x 14.0")	\$.50/page	\$.50/page	\$.50/page	\$.50/page	\$.50/page
General Photocopying, including RSA 91-A Right-to-Know Requests – single page (11.0" x 17.0")	\$.75/page	\$.75/page	\$.75/page	\$.75/page	\$.75/page
Copies of Appraisal Card for Property Owner	No charge	No charge	No charge	No charge	No charge
Copies of Appraisal Card for Requesters Other than Property Owner	\$1.00	\$1.00	\$1.00	\$1.00	\$1.00
Copies of Warranty Deed	\$1.00/page	\$1.00/page	\$1.00/page	\$1.00/page	\$1.00/page
Copies of Tax Map	\$2.00	\$2.00	\$2.00	\$2.00	\$2.00
Copies of Tax Bills for Property Owner	No charge	No charge	No charge	No charge	No charge
Copies of Tax Bills for Requesters Other than Property Owner	\$1.00	\$1.00	\$1.00	\$1.00	\$1.00
Electronic Files from Town Databases – on flashdrive or via email (no data filtering a/o manipulation)	\$25.00	\$25.00	\$30.00	\$30.00	\$30.00

Town of Hanover Schedule of Rates and Fees for FY2026 (July 1, 2025-June 30, 2026)

<u>Type of Fee</u>	<u>Adopted FY2021-22</u>	<u>Adopted FY2022-23</u>	<u>Adopted FY2023-24</u>	<u>Adopted FY2024-25</u>	<u>Proposed FY2025-26</u>
Public Voter Checklist – in any form (paper, e-mail, etc.)	\$25.00 for first 2,500 names on checklist plus \$.50 per thousand names or portion thereof in excess of 2,500; plus any shipping costs	\$25.00 for first 2,500 names on checklist plus \$.50 per thousand names or portion thereof in excess of 2,500; plus any shipping costs	\$25.00 for first 2,500 names on checklist plus \$.50 per thousand names or portion thereof in excess of 2,500; plus any shipping costs	\$25.00 for first 2,500 names on checklist plus \$.50 per thousand names or portion thereof in excess of 2,500; plus any shipping costs	\$25.00 for first 2,500 names on checklist plus \$.50 per thousand names or portion thereof in excess of 2,500; plus any shipping costs
Notary Public Services – per signature – Non-Residents	\$7.50	\$7.50	\$8.00	\$8.00	\$8.00
Notary Public Services – per signature for Hanover Residents (NH ID showing Hanover address must be presented)	No charge	No charge	No charge	No charge	No charge
Vendor Permit (Regular Size) - Daily	\$15.00	\$15.00	\$20.00	\$20.00	\$20.00
Vendor Permit for 9 Months beginning March 1 and ending November 30	\$1,200.00	\$1,200.00	\$1,300.00	\$1,300.00	\$1,300.00
Pole License	\$10.00	\$10.00	\$10.00	\$10.00	\$10.00
Articles of Agreement (Filing Fee)	\$5.00	\$5.00	\$5.00	\$5.00	\$5.00
Vital Statistics (e.g., Certified Copy of Birth Certificate)	\$15.00 for initial copy; \$10.00 for additional copies ordered at same time	\$15.00 for initial copy; \$10.00 for additional copies ordered at same time	\$15.00 for initial copy; \$10.00 for additional copies ordered at same time	\$15.00 for initial copy; \$10.00 for additional copies ordered at same time	\$15.00 for initial copy; \$10.00 for additional copies ordered at same time
Marriage License Fees (set by State of NH)	\$50.00	\$50.00	\$50.00	\$50.00	\$50.00
Conduit License Agreement	\$1.20/linear ft.	\$1.20/linear ft.	\$1.20/linear ft.	\$1.20/linear ft.	\$1.20/linear ft.
HIGHWAY					
Driveway Permits (DPW Review)	\$100.00	\$100.00	\$110.00	\$110.00	\$115.00
Private Construction - Class VI Highway Permit	\$100.00	\$100.00	\$100.00	\$100.00	\$100.00
Excavation Permits	\$100.00	\$100.00	\$110.00	\$110.00	\$115.00
Obstruction Permits	\$40.00	\$40.00	\$50.00	\$50.00	\$50.00
Project Inspection	\$85.00/hr	\$90.00/hr	\$90.00/hr	\$90.00/hr	\$100.00/hour

Town of Hanover Schedule of Rates and Fees for FY2026 (July 1, 2025-June 30, 2026)

HOWE LIBRARY & ETNA TOWN LIBRARY					
<u>Type of Fee</u>	<u>Adopted FY2021-22</u>	<u>Adopted FY2022-23</u>	<u>Adopted FY2023-24</u>	<u>Adopted FY2024-25</u>	<u>Proposed FY2025-26</u>
Out-of-State Inter-Library Loan Flat Fee	\$5.00	\$5.00	\$5.00	\$5.00	\$7.50
Museum Pass Non-Pickup Fee	\$5.00	\$5.00	\$5.00	\$5.00	\$5.00
Museum Pass Overdue Return Fee	\$5.00/day	\$5.00/day	\$5.00/day	\$5.00/day	\$5.00/day
Non-Resident Family – 12 Month Membership	\$140.00	\$140.00	\$140.00	\$140.00	\$140.00
Non-Resident Family – 3 Month Membership	\$60.00	\$60.00	\$60.00	\$60.00	\$60.00
Non-Resident Senior Citizen – 12 Month Membership (65+)	\$95.00	\$95.00	\$95.00	\$95.00	\$95.00
Dresden Employee Card	No charge	No charge	No charge	No charge	No charge
Non-Resident Childcare Providers	\$140.00	\$140.00	\$140.00	\$140.00	\$140.00
Copy and Print fee					\$.25/page

Town of Hanover Schedule of Rates and Fees for FY2026 (July 1, 2025-June 30, 2026)

PLANNING BOARD					
<u>Type of Fee</u>	<u>Adopted</u> <u>FY2021-22</u>	<u>Adopted</u> <u>FY2022-23</u>	<u>Adopted</u> <u>FY2023-24</u>	<u>Adopted</u> <u>FY2024-25</u>	<u>Proposed</u> <u>FY2025-26</u>
LCHIP fee* (<i>Land & Community</i>)	\$25.00	\$25.00	\$25.00	\$25.00	\$25.00
*Mandate by the State to record all Plans or Plan Sets					
*Separate certified check or money order required, made payable to "Grafton County Registry of Deeds"					
Legal Notice fee	\$75.00	\$75.00	\$75.00	\$75.00	\$75.00
Notification fee	\$10.00 PLUS USPS Certified Mail rate per name on Notification List	\$10.00 PLUS USPS Certified Mail rate per name on Notification List	\$10.00 PLUS USPS Certified Mail rate per name on Notification List	\$10.00 PLUS USPS Certified Mail rate per name on Notification List	\$10.00 PLUS USPS Certified Mail rate per name on Notification List
Registry fee	\$25.00 processing fee PLUS charge from Registry of Deeds	\$25.00 processing fee PLUS charge from Registry of Deeds	\$25.00 processing fee PLUS charge from Registry of Deeds	\$25.00 processing fee PLUS charge from Registry of Deeds	\$25.00 processing fee PLUS charge from Registry of Deeds
<u>Subdivision</u> (payable at time of design review application submission)					
Minor	\$325 base fee PLUS \$100/lot, plat, site or other division of land including units per RSA 672:14, PLUS LCHIP, Legal Notice, Notification, AND Registry	\$325 base fee PLUS \$100/lot, plat, site or other division of land including units per RSA 672:14, PLUS LCHIP, Legal Notice, Notification, AND Registry	\$325 base fee PLUS \$100/lot, plat, site or other division of land including units per RSA 672:14, PLUS LCHIP, Legal Notice, Notification, AND Registry	\$325 base fee PLUS \$100/lot, plat, site or other division of land including units per RSA 672:14, PLUS LCHIP, Legal Notice, Notification, AND Registry	\$325 base fee PLUS \$100/lot, plat, site or other division of land including units per RSA 672:14, PLUS LCHIP, Legal Notice, Notification, AND Registry

Town of Hanover Schedule of Rates and Fees for FY2026 (July 1, 2025-June 30, 2026)

<u>Type of Fee</u>	<u>Adopted FY2021-22</u>	<u>Adopted FY2022-23</u>	<u>Adopted FY2023-24</u>	<u>Adopted FY2024-25</u>	<u>Proposed FY2025-26</u>
Major	\$625 base fee PLUS \$150/lot, plat, site, or other division of land including units per RSA 672:14, PLUS LCHIP, Legal Notice, Notification, AND Registry	\$625 base fee PLUS \$150/lot, plat, site, or other division of land including units per RSA 672:14, PLUS LCHIP, Legal Notice, Notification, AND Registry	\$625 base fee PLUS \$150/lot, plat, site, or other division of land including units per RSA 672:14, PLUS LCHIP, Legal Notice, Notification, AND Registry	\$625 base fee PLUS \$150/lot, plat, site, or other division of land including units per RSA 672:14, PLUS LCHIP, Legal Notice, Notification, AND Registry	\$625 base fee PLUS \$150/lot, plat, site, or other division of land including units per RSA 672:14, PLUS LCHIP, Legal Notice, Notification, AND Registry
<u>Modification of Approval</u>					
Minor	\$200.00	\$200.00	\$200.00	\$200.00	\$200.00
SPR-Mnr	\$300.00	\$300.00	\$300.00	\$300.00	\$300.00
Major	\$500.00	\$500.00	\$500.00	\$500.00	\$500.00
<u>Site Plan Review</u>					
Minor Projects	\$75.00 PLUS Legal Notice, Notification AND \$5.00 per \$10,000 ECC	\$75.00 PLUS Legal Notice, Notification AND \$5.00 per \$10,000 ECC	\$75.00 PLUS Legal Notice, Notification AND \$5.00 per \$10,000 ECC	\$75.00 PLUS Legal Notice, Notification AND \$5.00 per \$10,000 ECC	\$75.00 PLUS Legal Notice, Notification AND \$5.00 per \$10,000 ECC
Major Projects	\$525.00 PLUS Legal Notice, Notification, PLUS:	\$525.00 PLUS Legal Notice, Notification, PLUS:	\$525.00 PLUS Legal Notice, Notification, PLUS:	\$525.00 PLUS Legal Notice, Notification, PLUS:	\$525.00 PLUS Legal Notice, Notification, PLUS:
\$0 to \$10,000,000 ECC	\$5.00 per \$10,000 of ECC	\$5.00 per \$10,000 of ECC	\$5.00 per \$10,000 of ECC	\$5.00 per \$10,000 of ECC	\$5.00 per \$10,000 of ECC
\$10,000,001 - \$30,000,000 ECC	\$3.00 per \$10,000 of ECC	\$3.00 per \$10,000 of ECC	\$3.00 per \$10,000 of ECC	\$3.00 per \$10,000 of ECC	\$3.00 per \$10,000 of ECC
\$30,000,001 and over ECC	\$1.00 per \$10,000 of ECC	\$1.00 per \$10,000 of ECC	\$1.00 per \$10,000 of ECC	\$1.00 per \$10,000 of ECC	\$1.00 per \$10,000 of ECC
<u>Modification of Approval</u>	\$500.00	\$500.00	\$500.00	\$500.00	\$500.00

Town of Hanover Schedule of Rates and Fees for FY2026 (July 1, 2025-June 30, 2026)

<u>Type of Fee</u>	<u>Adopted</u> <u>FY2021-22</u>	<u>Adopted</u> <u>FY2022-23</u>	<u>Adopted</u> <u>FY2023-24</u>	<u>Adopted</u> <u>FY2024-25</u>	<u>Proposed</u> <u>FY2025-26</u>
Certificate of Compliance Inspection	\$50.00 /inspection	\$50.00 /inspection	\$50.00 /inspection	\$50.00 /inspection	\$50.00 /inspection
Field Change	\$50.00	\$50.00	\$50.00	\$50.00	\$50.00
<u>Minor Lot Line Adjustment and Boundary Agreements</u>	\$150.00 PLUS LCHIP, Legal Notice, Notification AND Registry	\$150.00 PLUS LCHIP, Legal Notice, Notification AND Registry	\$150.00 PLUS LCHIP, Legal Notice, Notification AND Registry	\$150.00 PLUS LCHIP, Legal Notice, Notification AND Registry	\$150.00 PLUS LCHIP, Legal Notice, Notification AND Registry
<u>Lot Merger</u>	\$50.00 PLUS Registry	\$50.00 PLUS Registry	\$50.00 PLUS Registry	\$50.00 PLUS Registry	\$50.00 PLUS Registry

Town of Hanover Schedule of Rates and Fees for FY2026 (July 1, 2025-June 30, 2026)

ZONING & BUILDING PERMITS					
<u>Type of Fee</u>	<u>Adopted FY2021-22</u>	<u>Adopted FY2022-23</u>	<u>Adopted FY2023-24</u>	<u>Adopted FY2024-25</u>	<u>Proposed FY2025-26</u>
<u>Minimum Permit Fee</u>					
One- and Two-Family Residential	\$100.00	\$100.00	\$100.00	\$100.00	\$100.00
Commercial, Institutional, Multi-Family, and Other Non-One- and-Two-Family-residential construction	\$100.00	\$100.00	\$100.00	\$100.00	\$100.00
<u>One- and Two-Family Residential</u>	\$100 PLUS	\$100 PLUS	\$100 PLUS	\$100 PLUS	\$100 PLUS
Finished dwellings & additions, etc.	\$0.75/sf	\$0.75/sf	\$0.75/sf	\$0.75/sf	\$0.75/sf
Renovations, alterations, etc.	\$0.50/sf	\$0.50/sf	\$0.50/sf	\$0.50/sf	\$0.50/sf
Non-Habitable Structures (Porch, garage, shed, fence, pool, temporary trailer, retaining wall, etc.)	\$0.50/sf	\$0.50/sf	\$0.50/sf	\$0.50/sf	\$0.50/sf
<u>Commercial, Institutional, Multi-Family Residential</u> (All construction)	\$100 PLUS	\$100 PLUS	\$100 PLUS	\$100 PLUS	\$100 PLUS
	\$6.00 per \$1,000 of Construction Cost	\$6.00 per \$1,000 of Construction Cost	\$6.00 per \$1,000 of Construction Cost	\$6.00 per \$1,000 of Construction Cost	\$6.00 per \$1,000 of Construction Cost
<u>Sign, Awning, or Canopy</u>	\$100.00	\$100.00	\$100.00	\$100.00	\$100.00
<u>Parklet Application Fee</u> - for outdoor dining				\$50.00	\$50.00
<u>Moving or Demolition</u>	\$150.00	\$150.00	\$150.00	\$150.00	\$150.00
<u>Revision Plan Review and Partial Submissions</u>	\$75.00/hr (min 1 hour)	\$75.00/hr (min 1 hour)	\$75.00/hr (min 1 hour)	\$75.00/hr (min 1 hour)	\$75.00/hr (min 1 hour)
<u>Projects Requiring Outside Consulting Assistance</u> (where outside consulting services for plan review, testing or inspection are required)	The Town of Hanover has 30 days to review complete One- & Two-Family Project applications and 60 days to review complete Commercial & Multi-Family Projects & Properties under Condominium Ownership applications. In the event an applicant wants expedited review, or the Building Inspector deems the scope and complexity of the project to warrant outside review, the applicant shall, in addition to fees specified herein, pay costs of review by a third-party consultant selected by the Town.				
<u>Blanket Permit</u> per Project (Sec. IX of Building Code Adoption Ordinance)	\$50.00	\$50.00	\$75.00	\$75.00	\$75.00
<u>Application Resubmittal</u> (if filed 6 months or more after date of rejection, must file for new permitting)	\$100.00 for all projects	\$100.00 for all projects	\$100.00 for all projects	\$100.00 for all projects	\$100.00 for all projects
<u>Permit Extension</u>	\$50.00	\$50.00	\$100.00	\$100.00	\$100.00

Town of Hanover Schedule of Rates and Fees for FY2026 (July 1, 2025-June 30, 2026)

<u>Type of Fee</u>	<u>Adopted FY2021-22</u>	<u>Adopted FY2022-23</u>	<u>Adopted FY2023-24</u>	<u>Adopted FY2024-25</u>	<u>Proposed FY2025-26</u>
<u>Re-Inspection</u>	\$75.00	\$75.00	\$75.00	\$75.00	\$75.00
<u>Additional Inspection</u>	\$75.00	\$75.00	\$75.00	\$75.00	\$75.00
Request for <u>Life Safety Inspection</u> to enable occupancy prior to C.O. issuance					
To be paid prior to scheduling C.O. inspection	\$100.00	\$100.00*	\$100.00*	\$100.00*	\$100.00*
Permit Reinstatement - please note that the reinstatement of a building permit also requires reinstatement of a zoning permit, which is an additional fee	Half of the original Code Review fee or \$50.00, whichever is greater	\$100.00	\$100.00	\$100.00	\$100.00
<u>Deferred Electrical/Plumbing/Mechanical Submission</u>	\$75.00/hr (note: minimum \$75 1-hour fee)	\$75.00/hr (note: minimum \$75 1-hour fee)	\$75.00/hr (note: minimum \$75 1-hour fee)	\$75.00/hr (note: minimum \$75 1-hour fee)	\$75.00/hr (note: minimum \$75 1-hour fee)
<u>Administrative Fee for Beginning Work w/o Permits/Approvals</u>	\$300.00	\$300.00	\$300.00	\$300.00	\$300.00
<u>Health Inspection</u>	\$75.00 / Inspection	\$75.00 / Inspection	\$75.00 / Inspection	\$75.00 / Inspection	\$75.00 / Inspection
ZONING PERMIT ONLY	\$50.00	\$50.00	\$50.00	\$50.00	\$50.00
<u>Wetlands Administrative Permit</u>	\$50.00 PLUS cost to prepare and mail notices to abutters (\$5.00 PLUS USPS 1st Class mail rate per name on Notification List)	\$50.00 PLUS cost to prepare and mail notices to abutters (\$6.00 PLUS USPS 1st Class mail rate per name on Notification List)	\$50.00 PLUS cost to prepare and mail notices to abutters (\$6.00 PLUS USPS 1st Class mail rate per name on Notification List)	\$50.00 PLUS cost to prepare and mail notices to abutters (\$6.00 PLUS USPS 1st Class mail rate per name on Notification List)	\$50.00 PLUS cost to prepare and mail notices to abutters (\$6.00 PLUS USPS 1st Class mail rate per name on Notification List)
<u>Septic Design Review</u> (Prerequisite for DES Review)	\$50.00	\$50.00	\$100	\$100	\$100
<u>Driveway Permit (Zoning Review)</u>	\$50.00	\$50.00	\$50.00	\$50.00	\$50.00

Town of Hanover Schedule of Rates and Fees for FY2026 (July 1, 2025-June 30, 2026)

<u>Type of Fee</u>	<u>Adopted FY2021-22</u>	<u>Adopted FY2022-23</u>	<u>Adopted FY2023-24</u>	<u>Adopted FY2024-25</u>	<u>Proposed FY2025-26</u>
ZONING BOARD OF ADJUSTMENT					
<u>Legal Notice fee</u>	\$75.00	\$25.00	\$25.00	\$25.00	\$25.00
<u>Notification fee</u>	\$10.00 PLUS USPS Certified mail rate per name on Notification List	\$10.00 PLUS USPS Certified mail rate per name on Notification List	\$10.00 PLUS USPS Certified mail rate per name on Notification List	\$10.00 PLUS USPS Certified mail rate per name on Notification List	\$10.00 PLUS USPS Certified mail rate per name on Notification List
<u>Special Exception</u>	\$325.00 PLUS Legal Notice PLUS Notification	\$300.00 PLUS Legal Notice PLUS Notification	\$300.00 PLUS Legal Notice PLUS Notification	\$300.00 PLUS Legal Notice PLUS Notification	\$300.00 PLUS Legal Notice PLUS Notification
<u>Variance</u>	\$325.00 PLUS Legal Notice PLUS Notification	\$300.00 PLUS Legal Notice PLUS Notification	\$300.00 PLUS Legal Notice PLUS Notification	\$300.00 PLUS Legal Notice PLUS Notification	\$300.00 PLUS Legal Notice PLUS Notification
<u>Appeal of Administrative Decision</u>	\$325.00 PLUS Legal Notice PLUS Notification	\$300.00 PLUS Legal Notice PLUS Notification	\$300.00 PLUS Legal Notice PLUS Notification	\$300.00 PLUS Legal Notice PLUS Notification	\$300.00 PLUS Legal Notice PLUS Notification
<u>Equitable Waiver</u>	\$325.00 PLUS Legal Notice PLUS Notification	\$300.00 PLUS Legal Notice PLUS Notification	\$300.00 PLUS Legal Notice PLUS Notification	\$300.00 PLUS Legal Notice PLUS Notification	\$300.00 PLUS Legal Notice PLUS Notification
<u>Hearing Under RSA 674:41</u>	\$325.00 PLUS Legal Notice PLUS Notification	\$300.00 PLUS Legal Notice PLUS Notification	\$300.00 PLUS Legal Notice PLUS Notification	\$300.00 PLUS Legal Notice PLUS Notification	\$300.00 PLUS Legal Notice PLUS Notification
<u>Rehearing</u>	\$125.00 (PLUS Legal Notice & Notification, if granted)	\$100.00 (PLUS Legal Notice & Notification, if granted)	\$150.00 (PLUS Legal Notice & Notification, if granted)	\$150.00 (PLUS Legal Notice & Notification, if granted)	\$150.00 (PLUS Legal Notice & Notification, if granted)

Town of Hanover Schedule of Rates and Fees for FY2026 (July 1, 2025-June 30, 2026)

PLANNING, ZONING, CODE ENFORCEMENT-BUILDING SAFETY					
<u>Type of Fee</u>	<u>Adopted FY2021-22</u>	<u>Adopted FY2022-23</u>	<u>Adopted FY2023-24</u>	<u>Adopted FY2024-25</u>	<u>Proposed FY2025-26</u>
Fire Building Systems Review Fee (payable at time of design review application submission)					
Fire Permits: Stand-Alone Gas Installation and/or Replacement	\$60.00	\$60.00	\$75.00	\$75.00	\$75.00
Fire Permits: Additional Appliances (Gas) beyond Original Permit	\$20.00/per appliance	\$20.00/per appliance	\$20.00/per appliance	\$20.00/per appliance	\$20.00/per appliance
Fire Permits: Stand-Alone Oil Installation and/or Replacement	\$60.00	\$60.00	\$75.00	\$75.00	\$75.00
Fire Permits: Additional Appliances (Oil) beyond Original Permit	\$20.00/per appliance	\$20.00/per appliance	\$20.00/per appliance	\$20.00/per appliance	\$20.00/per appliance
Re-inspection Fee – Gas or Oil	\$110.00	\$110.00	\$110.00	\$110.00	\$110.00
Projects Requiring Outside Consulting Assistance (where outside consulting services for plan review, testing or inspection are required)	Full cost +10% admin charge	Full cost +10% admin charge	Full cost +10% admin charge	Full cost +10% admin charge	Full cost +10% admin charge
RENTAL HOUSING REGISTRATION AND INSPECTION					
Rental Housing Registration			\$50.00	\$50.00	\$50.00
Rental Housing Inspection			\$250.00	\$250.00	\$250.00
Reinspection			\$75.00	\$75.00	\$75.00
Transfer of Permit			\$25.00	\$25.00	\$25.00
Failure to register or renew			\$150.00	\$150.00	\$150.00

Town of Hanover Schedule of Rates and Fees for FY2026 (July 1, 2025-June 30, 2026)

POLICE DEPARTMENT					
<u>Type of Fee</u>	<u>Adopted FY2021-22</u>	<u>Adopted FY2022-23</u>	<u>Adopted FY2023-24</u>	<u>Adopted FY2024-25</u>	<u>Proposed FY2025-26</u>
Pistol Permits (5 year Permit)	\$10.00	\$10.00	\$10.00	\$10.00	\$10.00
Special Services Detail – Police Personnel (per hour)	\$70.00	\$70.00	\$80.00	\$80.00	\$100.00
Special Services Detail <i>Non-Profit</i> – Police Personnel (per hour)	<i>Non-Profits may qualify for reduction in the special detail</i>	\$65.00	\$75.00	\$75.00	\$80.00
Special Services Detail - Cruiser Fee (where cruiser is part of alert presence)	\$20.00/hour	\$20.00/hour	\$25.00/hour	\$25.00/hour	\$0.00
Copies of Police Reports	actual copying costs @ \$0.25/page	actual copying costs @ \$0.25/page	actual copying costs @ \$0.25/page	actual copying costs @ \$0.25/page	actual copying costs @ \$0.25/page
Fingerprints - Hanover Residents and Hanover Businesses	\$25.00	\$25.00	\$30.00	\$30.00	\$30.00
Fingerprints - Non-residents	\$50.00	\$50.00	\$55.00	\$55.00	\$55.00
Digital Images from Police Reports (e.g., photos on CD, DVD of Cruiser Video used for Discovery)	\$25.00	\$25.00	\$25.00	\$25.00	\$25.00
Alarm Connection Fee – One-Time Charge	\$100.00	\$90.00	\$100.00	\$100.00	\$100.00
Annual Alarm Monitoring Fee	\$385.00 within Town; \$485.00 out-of-Town pro-rated monthly	\$385.00 within Town; \$485.00 out-of-Town pro-rated monthly	\$400.00 within Town; \$500.00 out-of-Town pro-rated monthly	\$400.00 within Town; \$500.00 out-of-Town pro-rated monthly	\$425.00 within Town; \$525.00 out-of-Town pro-rated monthly
Police Service in response to alarm – Residential	\$55.00	\$55.00	\$55.00	\$55.00	\$75.00
Police Service in response to alarm – Commercial	\$55.00	\$55.00	\$55.00	\$55.00	\$75.00
Penalty Charge for Inaccurate Call List related to alarm monitoring	\$15.00	\$15.00	\$15.00	\$15.00	\$15.00

Town of Hanover Schedule of Rates and Fees for FY2026 (July 1, 2025-June 30, 2026)

<u>Type of Fee</u>	<u>Adopted</u> <u>FY2021-22</u>	<u>Adopted</u> <u>FY2022-23</u>	<u>Adopted</u> <u>FY2023-24</u>	<u>Adopted</u> <u>FY2024-25</u>	<u>Proposed</u> <u>FY2025-26</u>
<u>Dog License</u> – Neutered Male and Female; and Puppies Under 7 Mos.	\$7.50	\$7.50	\$7.50	\$7.50	\$7.50
<u>Dog License</u> – Unneutered Male and Female	\$10.00	\$10.00	\$10.00	\$10.00	\$10.00
<u>Dog License</u> – First Dog – Sr. Citizen Owner	\$3.00	\$3.00	\$3.00	\$3.00	\$3.00
<u>Dog License</u> – Group License for 5 or more Dogs	\$21.00	\$21.00	\$21.00	\$21.00	\$21.00
<u>Dog License</u> – Late Fee per Month after May 31	\$1.00	\$1.00	\$1.00	\$1.00	\$1.00
<u>Dog License</u> – Replacement Tag and License #	\$3.00	\$3.00	\$3.00	\$3.00	\$3.00
Nuisance Dog Fine	\$25.00	\$25.00	\$25.00	\$25.00	\$25.00
Menace Dog Fine	\$50.00	\$50.00	\$50.00	\$50.00	\$50.00
Vicious Dog Fine	\$100.00	\$100.00	\$100.00	\$100.00	\$100.00
Unlicensed Dog Fine	\$25.00	\$25.00	\$25.00	\$25.00	\$25.00
Skateboarding in violation of Ordinance #2	First Offense \$25.00, Subsequent \$100.00	First Offense \$25.00, Subsequent \$100.00	First Offense \$25.00, Subsequent \$100.00	First Offense \$25.00, Subsequent \$100.00	First Offense \$25.00, Subsequent \$100.00
Bicycling in violation of Ordinance #2	First Offense \$25.00, Subsequent \$100.00	First Offense \$25.00, Subsequent \$100.00	First Offense \$25.00, Subsequent \$100.00	First Offense \$25.00, Subsequent \$100.00	First Offense \$25.00, Subsequent \$100.00
Illegal U-Turn in violation of Ordinance #7	First Offense \$50.00, Subsequent \$100.00	First Offense \$50.00, Subsequent \$100.00	First Offense \$50.00, Subsequent \$100.00	First Offense \$50.00, Subsequent \$100.00	First Offense \$50.00, Subsequent \$100.00
Open Container in violation of Ordinance #32	First Offense \$50.00, Subsequent \$200.00	First Offense \$50.00, Subsequent \$200.00	First Offense \$50.00, Subsequent \$200.00	First Offense \$50.00, Subsequent \$200.00	First Offense \$50.00, Subsequent \$200.00

Town of Hanover Schedule of Rates and Fees for FY2026 (July 1, 2025-June 30, 2026)

PARKING DIVISION					
<u>Type of Fee</u>	<u>Adopted FY2021-22</u>	<u>Adopted FY2022-23</u>	<u>Adopted FY2023-24</u>	<u>Adopted FY2024-25</u>	<u>Proposed FY2025-26</u>
<u>Lot Rentals – CBD (Commercial Business District) Space Monthly Rentals</u>	\$90.00	\$90.00	\$115.00	\$115.00	\$115.00
<u>Lot Rentals (Lease w/6 mo. Commitment) – Facility Space Monthly Rentals no specific level</u>	\$135.00	\$135.00	\$150.00	\$150.00	\$150.00
<u>Lot Rentals – ZBA (Zoning Board of Adjustment) Required Monthly Lot Rentals</u>	\$82.50/space	\$82.50/space	\$82.50/space	\$82.50/space	\$82.50/space
<u>Parklet Parking Space Offset Fee</u>				\$250.00/space	\$250.00/space
<u>Sidewalk Seating - Table and 4 Chairs (Ord #41)</u>				\$250.00/table	\$250.00/table
<u>Temporary Parking Permits (M-F, 9-5)</u>	\$20.00/day	\$20.00/day	\$20.00/day	\$20.00/day	\$20.00/day
<u>Reserved Space / Meter Rental (24 hours a day, 7 Days a week)</u>	\$25.00/day	\$25.00/day	\$25.00/day	\$25.00/day	\$25.00/day
<u>Hovey Lane and lower Lebanon Street Permit Parking - 2-Month Permit thru 12/31/22, 1-Month Permit effective 1/1/2023</u>	\$80.00	\$40.00	\$55.00	\$55.00	\$55.00
<u>Annual Parking Permits – Replacement of Lost or Misplaced Permits</u>	\$10.00	\$10.00	\$10.00	\$10.00	\$10.00
<u>Duplicate Permit Fee - Fee for extra permit</u>				\$10.00	\$10.00
Town Parking Garage Rates - Please Note: Total Parking Facility Charge Increases					
Town Parking Garage - Short Term Rates - Monday-Friday 7:00am-9:00pm, Saturday 9:00am-6:00pm, Sundays free	Hourly Rate / Total \$	Hourly Rate / Total \$	Hourly Rate / Total \$	Hourly Rate / Total \$	Hourly Rate / Total \$
Town Parking Garage – Short Term Rates – Grace Period Exit Before 10-Minutes	\$-0-	\$-0-	\$-0-	\$-0-	\$-0-
Town Parking Garage – Short Term Rates – <i>Minimum Charge 10- to 30-Minutes</i>	\$0.50 / \$0.50	\$0.50 / \$0.50	\$1.00/\$1.00	\$1.00/\$1.00	\$1.00/\$1.00
Town Parking Garage – Short Term Rates – <i>2nd Half Hour</i>	\$0.50 / \$1.00	\$0.50 / \$1.00	\$1.00/\$2.00	\$1.00/\$2.00	\$1.00/\$2.00
Town Parking Garage – Short Term Rates – <i>2nd Hour</i>	\$1.00 / \$2.00	\$1.00 / \$2.00	\$1.50/\$3.50	\$1.50/\$3.50	\$1.50/\$3.50
Town Parking Garage – Short Term Rates – <i>3rd Hour</i>	\$1.00 / \$3.00	\$1.00 / \$3.00	\$1.50/\$5.00	\$1.50/\$5.00	\$1.50/\$5.00
Town Parking Garage – Short Term Rates – <i>4th Hour</i>	\$3.00 / \$6.00	\$3.00 / \$6.00	\$3.00/\$6.00	\$1.00/\$6.00	\$1.00/\$6.00
Town Parking Garage – Short Term Rates – <i>5th Hour</i>	\$3.00 / \$9.00	\$3.00 / \$9.00	\$3.00/\$9.00	\$3.00/\$9.00	\$3.00/\$9.00
Town Parking Garage – Short Term Rates – <i>6th Hour</i>	\$3.00 / \$12.00	\$3.00 / \$12.00	\$3.00/\$12.00	\$3.00/\$12.00	\$3.00/\$12.00
Town Parking Garage – Short Term Rates – <i>7th Hour</i>	\$3.00 / \$15.00	\$3.00 / \$15.00	\$3.00/\$15.00	\$3.00/\$15.00	\$3.00/\$15.00
Town Parking Garage – Short Term Rates – <i>8th Hour and Over</i>	\$5.00 / \$20.00	\$5.00 / \$20.00	\$5.00/\$20.00	\$5.00/\$20.00	\$5.00/\$20.00
Town Parking Garage – Validation Stickers: One Hour @ \$1.00 each (minimum purchase 96)	\$72.00	\$72.00	\$72.00	\$96.00	\$96.00
Town Parking Garage – Validation Stickers: All-Day @ \$20.00 each (minimum purchase 10)	\$200.00	\$200.00	\$200.00	\$200.00	\$200.00
Downtown Employee Permits			\$8.00/day	\$8.00/day	\$8.00/day

Town of Hanover Schedule of Rates and Fees for FY2026 (July 1, 2025-June 30, 2026)

Type of Fee	<u>Adopted</u> FY2021-22	<u>Adopted</u> FY2022-23	<u>Adopted</u> FY2023-24	<u>Adopted</u> FY2024-25	<u>Proposed</u> FY2025-26
Short Term Lease (Up to 6 months)			\$175.00/month	\$175.00/month	\$175.00/month
Long-Term Lease (6 months or more)			\$150.00/month	\$150.00/month	\$150.00/month
Late fee for lease non-payment			\$30.00	\$30.00	\$30.00
Town Parking Garage - Electric Car Charging Station Fee	\$1.50/hour	\$1.50/hour	\$2.00/hour	\$2.00/hour	\$2.00/hour
Meter Rates - Please Note: Meter Rate Charge Increases					
<u>Meter Rates</u> – for 2-Hour and 3-Hour Limit *On Street* Metered Areas and Municipal Lot 1	\$.05 = 2 min; \$.10 = 4 min; \$.25 = 10 min; \$1.00 coin = 40 min	\$.05 = 2 min; \$.10 = 4 min; \$.25 = 10 min; \$1.00 coin = 40 min	\$.05 = 2 min; \$.10 = 4 min; \$.25 = 10 min	\$.05 = 2 min; \$.10 = 4 min; \$.25 = 10 min	\$.05 = 2 min; \$.10 = 4 min; \$.25 = 10 min
<u>Meter Rates</u> – for 2-Hour and 3-Hour Limit *Off Street* Metered Areas *except Municipal Lot 1*	\$.05 = 3 min; \$.10 = 6 min; \$.25 = 15 min; \$1.00 coin = 60 min (1 hr)	\$.05 = 3 min; \$.10 = 6 min; \$.25 = 15 min; \$1.00 coin = 60 min (1 hr)	\$.05 = 3 min; \$.10 = 6 min; \$.25 = 15 min	\$.05 = 3 min; \$.10 = 6 min; \$.25 = 15 min	\$.05 = 3 min; \$.10 = 6 min; \$.25 = 15 min
<u>Meter Rates</u> – for 10-Hour Limit Meter Areas	\$.05 = 6 min; \$.10 = 12 min; \$.25 = 30 min; \$1.00 coin = 120 min (2 hr)	\$.05 = 6 min; \$.10 = 12 min; \$.25 = 30 min; \$1.00 coin = 120 min (2 hr)	\$.05 = 3 min; \$.10 = 7 min; \$.25 = 20 min; \$.75 = 60 min	\$.05 = 3 min; \$.10 = 7 min; \$.25 = 20 min; \$.75 = 60 min	\$.05 = 3 min; \$.10 = 7 min; \$.25 = 20 min; \$.75 = 60 min
<u>Meter Violations</u> – Expired Meter	\$15.00	\$15.00	\$15.00	\$15.00	\$15.00
Meter Violations – Fine After 14 Days	\$25.00	\$30.00	\$30.00	\$30.00	\$30.00
Meter Violations – Fine After 28 Days	\$35.00	\$40.00	\$40.00	\$40.00	\$40.00
<u>Meter Violations</u> – Overtime Violation (2 Hr. Zone)	\$30.00	\$30.00	\$30.00	\$30.00	\$30.00
Meter Violations – Fine After 14 Days	\$60.00	\$60.00	\$60.00	\$60.00	\$60.00
Meter Violations – Fine After 28 Days	\$70.00	\$70.00	\$70.00	\$70.00	\$70.00
<u>Meter Violations</u> – Overtime Meter Feeding	\$25.00	\$25.00	\$25.00	\$25.00	\$25.00
Meter Violations – Fine After 14 Days	\$40.00	\$50.00	\$50.00	\$50.00	\$50.00
Meter Violations – Fine After 28 Days	\$50.00	\$60.00	\$60.00	\$60.00	\$60.00
<u>Meter Violations</u> – 2nd Meter Ticket This Date	\$20.00	\$20.00	\$20.00	\$20.00	\$20.00
Meter Violations – Fine After 14 Days	\$30.00	\$40.00	\$40.00	\$40.00	\$40.00
Meter Violations – Fine After 28 Days	\$40.00	\$50.00	\$50.00	\$50.00	\$50.00
<u>Meter Violations</u> – 3rd Meter Ticket This Date	\$30.00	\$30.00	\$30.00	\$30.00	\$30.00
Meter Violations – Fine After 14 Days	\$60.00	\$60.00	\$60.00	\$60.00	\$60.00
Meter Violations – Fine After 28 Days	\$70.00	\$70.00	\$70.00	\$70.00	\$70.00
<u>Meter Violations</u> – Towing Charge (Winter Parking Ban)	\$150.00	\$200.00	\$200.00	\$200.00	\$200.00
Meter Violations – Fine After 14 Days	\$200.00	\$250.00	\$250.00	\$250.00	\$250.00
Meter Violations – Fine After 28 Days	\$210.00	\$250.00	\$260.00	\$260.00	\$260.00
<u>Meter Violations</u> – Handicapped Space	\$500.00	\$500.00	\$500.00	\$500.00	\$500.00
Meter Violations – Fine After 14 Days	\$1,000.00	\$1,000.00	\$1,000.00	\$1,000.00	\$1,000.00
Meter Violations – Fine After 28 Days	\$1,000.00	\$1,000.00	\$1,000.00	\$1,000.00	\$1,000.00

Town of Hanover Schedule of Rates and Fees for FY2026 (July 1, 2025-June 30, 2026)

Type of Fee	<u>Adopted</u> <u>FY2021-22</u>	<u>Adopted</u> <u>FY2022-23</u>	<u>Adopted</u> <u>FY2023-24</u>	<u>Adopted</u> <u>FY2024-25</u>	<u>Proposed</u> <u>FY2025-26</u>
Meter Violations – No Parking 12:01AM – 7:00AM; 2:00AM – 6:00AM	\$30.00	\$30.00	\$30.00	\$30.00	\$30.00
Meter Violations – Fine After 14 Days	\$60.00	\$60.00	\$60.00	\$60.00	\$60.00
Meter Violations – Fine After 28 Days	\$70.00	\$70.00	\$70.00	\$70.00	\$70.00
Meter Violations – Parking in Prohibited Zone	\$30.00	\$30.00	\$30.00	\$30.00	\$30.00
Meter Violations – Fine After 14 Days	\$60.00	\$60.00	\$60.00	\$60.00	\$60.00
Meter Violations – Fine After 28 Days	\$70.00	\$70.00	\$70.00	\$70.00	\$70.00
Meter Violations – Parking in Prohibited Zone *Enhanced Fine*	\$40.00	\$40.00	\$40.00	\$40.00	\$40.00
Meter Violations – Fine After 14 Days	\$80.00	\$80.00	\$80.00	\$80.00	\$80.00
Meter Violations – Fine After 28 Days	\$90.00	\$90.00	\$90.00	\$90.00	\$90.00
Meter Violations – No Town Permit	\$30.00	\$30.00	\$30.00	\$30.00	\$30.00
Meter Violations – Fine After 14 Days	\$60.00	\$60.00	\$60.00	\$60.00	\$60.00
Meter Violations – Fine After 28 Days	\$70.00	\$70.00	\$70.00	\$70.00	\$70.00
Meter Violations – Left Wheels to Curb	\$30.00	\$30.00	\$30.00	\$30.00	\$30.00
Meter Violations – Fine After 14 Days	\$60.00	\$60.00	\$60.00	\$60.00	\$60.00
Meter Violations – Fine After 28 Days	\$70.00	\$70.00	\$70.00	\$70.00	\$70.00
Meter Violations – Loading/Bus Zone	\$75.00	\$75.00	\$75.00	\$75.00	\$75.00
Meter Violations – Fine After 14 Days	\$150.00	\$150.00	\$150.00	\$150.00	\$150.00
Meter Violations – Fine After 28 Days	\$160.00	\$160.00	\$160.00	\$160.00	\$160.00
Meter Violations – Improper Parking	\$30.00	\$30.00	\$30.00	\$30.00	\$30.00
Meter Violations – Fine After 14 Days	\$60.00	\$60.00	\$60.00	\$60.00	\$60.00
Meter Violations – Fine After 28 Days	\$70.00	\$70.00	\$70.00	\$70.00	\$70.00
Meter Violations – Parking on Sidewalk	\$30.00	\$30.00	\$30.00	\$30.00	\$30.00
Meter Violations – Fine After 14 Days	\$60.00	\$60.00	\$60.00	\$60.00	\$60.00
Meter Violations – Fine After 28 Days	\$70.00	\$70.00	\$70.00	\$70.00	\$70.00
Meter Violations – Parking in Restricted Area	\$30.00	\$30.00	\$30.00	\$30.00	\$30.00
Meter Violations – Fine After 14 Days	\$60.00	\$60.00	\$60.00	\$60.00	\$60.00
Meter Violations – Fine After 28 Days	\$70.00	\$70.00	\$70.00	\$70.00	\$70.00
Meter Violations – Parking in Violation of Site Plan Approval	\$50.00	\$50.00	\$50.00	\$50.00	\$50.00
Meter Violations – Fine After 14 Days	\$75.00	\$100.00	\$100.00	\$100.00	\$100.00
Meter Violations – Fine After 28 Days	\$100.00	\$110.00	\$110.00	\$110.00	\$110.00
Boot Removal Fee	\$50.00	\$50.00	\$50.00	\$50.00	\$50.00

Town of Hanover Schedule of Rates and Fees for FY2026 (July 1, 2025-June 30, 2026)

PARKS & RECREATION DEPARTMENT

<u>Type of Fee</u>	<u>Adopted FY2021-22</u>	<u>Adopted FY2022-23</u>	<u>Adopted FY2023-24</u>	<u>Adopted FY2024-25</u>	<u>Proposed FY2025-26</u>
Athletic Programs Resident Fees	\$57.00	\$60.00	\$62.00	\$65.00	\$65.00
Athletic Programs NON-Resident Fees	\$67.00	\$70.00	\$72.00	\$75.00	\$75.00
Lacrosse Programs Resident Fees			\$72.00	\$75.00	\$75.00
Lacrosse Programs NON-Resident Fees			\$82.00	\$85.00	\$85.00
Athletic Programs All Basketball Participants – Facilities Usage Fee Made Payable to SAU #70	\$41.00	\$73.00	\$73.00	\$73.00	\$73.00
Late Registration Fee for Registrations Received after Deadline	\$26.00	\$26.00	\$26.00	\$26.00	\$26.00
Instructional Athletic Programs Resident Fees	\$36.00	\$40.00	\$40.00	\$40.00	\$45.00
Instructional Athletic Programs Non-Resident Fees	\$46.00	\$50.00	\$50.00	\$50.00	\$55.00
Instructional Programs Late Registration Fee for Registrations Received after Deadline			\$12.00	\$12.00	\$26.00
Uniform Deposit Fee	\$67.00	\$70.00	\$70.00	\$70.00	\$70.00
OST KAST monthly – 5 day enrollment	\$361.00	\$375.00	\$375.00	\$375.00	\$375.00
OST KAST monthly – 4 day enrollment	\$294.00	\$305.00	\$305.00	\$305.00	\$305.00
OST KAST monthly – 3 day enrollment	\$227.00	\$235.00	\$235.00	\$235.00	\$235.00
OST KAST monthly – 2 day enrollment	\$160.00	\$165.00	\$165.00	\$165.00	\$165.00
OST KAST monthly – 1 day enrollment				\$85.00	\$88.00
OST KAST – Drop-In (if space is available)	\$26.00/day \$36.00/Wed.	\$27.00/day \$37.00/Wed.	\$30.00/day \$40.00/Wed.	\$30.00/day \$40.00/Wed.	\$30.00/day \$40.00/Wed.
School Year PLAY weekly- 5 days			\$90.00	\$90.00	N/A
School Year PLAY weekly-3 days			\$75.00	\$75.00	N/A
School Year PLAY weekly- 2 days			\$50.00	\$50.00	N/A
OST (Out of School Time) Program – Late Pick-up Fee	Between one to thirty minutes late: \$1.00 per minute with a minimum \$10.00 charge. More than thirty minutes late: \$2.00 per minute.	Between one to thirty minutes late: \$1.00 per minute with a minimum \$10.00 charge. More than thirty minutes late: \$2.00 per minute.	Between one to thirty minutes late: \$1.00 per minute with a minimum \$10.00 charge. More than thirty minutes late: \$2.00 per minute.	Between one to thirty minutes late: \$1.00 per minute with a minimum \$10.00 charge. More than thirty minutes late: \$2.00 per minute.	Between one to thirty minutes late: \$1.00 per minute with a minimum \$10.00 charge. More than thirty minutes late: \$2.00 per minute.
KAST (Kids After School Time) – Late Payment Fee	\$25.00 if payment not made by the 4th of the month	\$25.00 if payment not made by the 4th of the month	\$25.00 if payment not made by the 4th of the month	\$25.00 if payment not made by the 4th of the month	\$25.00 if payment not made by the 4th of the month
KAST Schedule Change Fee (after registration)	1 st occurrence free; each additional \$10	1 st occurrence free; each additional \$10	1 st occurrence free; each additional \$10	1 st occurrence free; each additional \$10	1 st occurrence free; each additional \$10
KAST Membership Fee	\$26.00	\$28.00	\$28.00	\$28.00	\$30.00
Summer Camp Membership Fee	\$26.00	\$28.00	\$28.00	\$28.00	\$30.00
Summer Camp Resident Weekly Fee	N/A	N/A	\$225.00	\$225.00	\$250.00

Town of Hanover Schedule of Rates and Fees for FY2026 (July 1, 2025-June 30, 2026)

<u>Type of Fee</u>	<u>Adopted FY2021-22</u>	<u>Adopted FY2022-23</u>	<u>Adopted FY2023-24</u>	<u>Adopted FY2024-25</u>	<u>Proposed FY2025-26</u>
Summer Camp Non Resident Weekly Fee	N/A	N/A	\$250.00	\$250.00	\$275.00
Summer Camp Resident 2-Week Fee	\$300.00	\$310.00	N/A	N/A	N/A
Summer Camp Non Resident 2-Week Fee	\$510.00	\$525.00	N/A	N/A	N/A
Summer PLAY weekly- 5 days	\$90.00	\$90.00	\$90.00	\$120.00	\$125.00
Summer PLAY Non-resident weekly- 5 days	N/A	N/A	N/A	\$145.00	\$150.00
Summer PLAY weekly-3 days	\$75.00	\$75.00	\$75.00	\$75.00	\$80.00
Summer PLAY Non-resident weekly- 3 days	N/A	N/A	N/A	\$100.00	\$105.00
Summer PLAY weekly- 2 days	\$50.00	\$50.00	\$50.00	\$50.00	\$55.00
Summer PLAY Non-resident weekly- 2 days	N/A	N/A	N/A	\$75.00	\$80.00
QUEST Mini-Camps – Resident Weekly Fees	\$205.00	\$215.00	\$250.00	\$275.00	\$300.00
QUEST Mini-Camps – Non-Resident Weekly Fees	\$285.00	\$295.00	\$300.00	\$300.00	\$325.00
Mini Camps- Feb, April, Outdoor Adventures Resident Weekly Fees				\$275.00	\$275.00
Mini-Camps – Non-Resident Weekly Fees				\$300.00	\$300.00
Mini-Camps – Resident Daily Fee			\$60.00	\$60.00	\$65.00
Mini-Camps – Non-Resident Daily Fee			\$70.00	\$70.00	\$75.00
PLAY- 1/2 Day Program (monthly)			\$520.00	\$585.00	N/A
Adult and Youth Instructional Programs – Fees Determined Based on Instructors’ Costs and Administrative and Materials Costs; Program Revenue is split 70/30 between the Instructor and the Recreation Department; Instructor may keep 70% of total income earned up to a maximum of \$75.00/hour after expenses.	varies	varies	varies	varies	varies
Athletic Field Rental	\$36/hour for Hanover Youth Activities; \$46/hour for Youth Activities; \$206/week for Hanover Youth Sports Seasons; \$77/hour for Adult Activities	\$46/hour for Hanover Community Youth Sports; \$206/week for Hanover Community Youth Sports Seasons; \$77/hour for Hanover Community Adult Sports; \$100/hour for Non-Town Sponsored Groups/Commercial Activities	\$50/hour for Hanover Community Youth Sports; \$215/week for Hanover Community Youth Sports Seasons; \$80/hour for Hanover Community Adult Sports; \$110/hour for Non-Town Sponsored Groups/Commercial Activities	\$50/hour for Hanover Community Youth Sports; \$215/week for Hanover Community Youth Sports Seasons; \$80/hour for Hanover Community Adult Sports; \$110/hour for Non-Town Sponsored Groups/Commercial Activities	\$65/hour for Hanover Community Youth Sports; \$215/week for Hanover Community Youth Sports Seasons; \$85/hour for Hanover Community Adult Sports; \$150/hour for Non-Town Sponsored Groups/Commercial Activities

Town of Hanover Schedule of Rates and Fees for FY2026 (July 1, 2025-June 30, 2026)

<u>Type of Fee</u>	<u>Adopted</u> <u>FY2021-22</u>	<u>Adopted</u> <u>FY2022-23</u>	<u>Adopted</u> <u>FY2023-24</u>	<u>Adopted</u> <u>FY2024-25</u>	<u>Proposed</u> <u>FY2025-26</u>
Lining of Athletic Field	Per Field: \$154 for Hanover Youth Organizations \$309 for All Others	Per Field: \$175 for Hanover Youth Organizations \$350 for All Others	Per Field: \$200 for Hanover Youth Organizations \$350 for All Others	Per Field: \$200 for Hanover Youth Organizations \$350 for All Others	Per Field: \$300 for Hanover Youth Organizations \$450 for All Others
Basketball Tournament Fees per Team	\$85.00	\$85.00	\$100.00	\$100.00	\$100.00
Middle School Dance Admission	\$5.00	\$10.00	\$10.00	\$10.00	N/A

Town of Hanover Schedule of Rates and Fees for FY2026 (July 1, 2025-June 30, 2026)

<u>Type of Fee</u>	<u>Adopted</u> <u>FY2021-22</u>	<u>Adopted</u> <u>FY2022-23</u>	<u>Adopted</u> <u>FY2023-24</u>	<u>Adopted</u> <u>FY2024-25</u>	<u>Proposed</u> <u>FY2025-26</u>
RWB COMMUNITY CENTER FEES					
<i>Security and Key Deposits will be reviewed on</i>					
HPR Programs, Town of Hanover Functions, or organizations working with HPR offering free community events.	No Fee	No Fee	No Fee	No Fee	No Fee
Resident or Non Profit Groups <i>(certificate of non profit status required)</i>					
Week Day Hourly Rate: Peak Hours	\$30.00	\$40.00	\$40.00	\$40.00	\$40.00
Week Day Hourly Rate: Non-Peak Hours			\$30.00	\$30.00	\$30.00
Week Day Multi-Purpose Room Group Size LESS than 35	\$30.00	\$40.00	\$40.00	\$40.00	\$40.00
Week Day Multi-Purpose Room Group Size MORE than 35	\$40.00	\$50.00	\$50.00	\$50.00	\$50.00
Weekend Multi-Purpose Room Group Size LESS than 35 (4 hour time block)	\$120.00	\$150.00	\$150.00	\$150.00	\$150.00
Weekend Multi-Purpose Room Group Size MORE than 35 (4 hour time block)	\$180.00	\$200.00	\$200.00	\$200.00	\$200.00
Non-Resident and all other Groups					
Week Day Hourly Rate	\$40.00	\$50.00	\$50.00	\$50.00	\$50.00
Week Day Multi-Purpose Room Group Size LESS than 35	\$40.00	\$50.00	\$50.00	\$50.00	\$50.00
Week Day Multi-Purpose Room Group Size MORE than 35	\$50.00	\$60.00	\$60.00	\$60.00	\$60.00
Weekend Multi-Purpose Room Group Size LESS than 35 (4 hour time block)	\$160.00	\$190.00	\$190.00	\$190.00	\$190.00
Weekend Multi-Purpose Room Group Size MORE than 35 (4 hour time block)	\$220.00	\$240.00	\$240.00	\$240.00	\$240.00
Monthly Basement Storage Fee for groups with recurring rentals.	\$25 - \$50	\$25 - \$50	\$25 - \$50	\$25 - \$50	\$25 - \$50
Hourly rate for staff set up/take down during normal operating hours.	\$75.00	\$125.00	\$125.00	\$125.00	\$125.00
Bounce House Rental	\$45.00	\$45.00	\$45.00	\$45.00	\$45.00
Renter's Fee for RWB Damage	n/a	\$250.00	\$250.00	\$250.00	\$250.00
Hourly rate for add'l. cleaning if needed	\$150.00	\$250.00	\$250.00	\$250.00	\$250.00
TENNEY PARK PAVILION					
Residents Hourly Rate	\$26.00	\$30.00	\$35.00	\$35.00	\$35.00
Non-Residents Hourly Rate	\$41.00	\$40.00	\$45.00	\$45.00	\$45.00
<i>Fundraising Events</i>					
Hanover Based Groups Hourly Rate	\$46.00	\$46.00	\$50.00	\$50.00	\$50.00
Dresden School District Groups Hourly Rate	\$52.00	\$52.00	\$55.00	\$55.00	\$55.00
Non-Hanover Based Groups:	\$72.00	\$75.00	\$75.00	\$75.00	\$75.00
All Other Organizations Hourly Rate	\$77.00	\$80.00	\$85.00	\$85.00	\$85.00

Town of Hanover Schedule of Rates and Fees for FY2026 (July 1, 2025-June 30, 2026)

<u>Type of Fee</u>	<u>Adopted</u> <u>FY2021-22</u>	<u>Adopted</u> <u>FY2022-23</u>	<u>Adopted</u> <u>FY2023-24</u>	<u>Adopted</u> <u>FY2024-25</u>	<u>Proposed</u> <u>FY2025-26</u>
PUBLIC GROUNDS					
Cemetery Lots - Hanover Residents	\$700.00	\$700.00	\$700.00	\$700.00	\$700.00
Cemetery Lots - Non-Residents	\$2,050.00	\$2,050.00	\$2,050.00	\$2,200.00	\$2,200.00
Interment - Weekday	\$650.00	\$700.00	\$700.00	\$700.00	\$700.00
Cremation/Urn Interment - Weekday	\$300.00	\$250.00	\$250.00	\$300.00	\$300.00
Interment - Weekend	n/a	\$800.00	\$800.00	\$800.00	\$800.00
Cremation/Urn Interment - Weekend	n/a	\$400.00	\$400.00	\$400.00	\$400.00
Winter (November-March) Interment Additional Fee-Full Burial	\$100.00	\$100.00	\$100.00	\$100.00	\$100.00
Winter (November-March) Interment Additional Fee-Cremation	\$50.00	\$50.00	\$50.00	\$50.00	\$50.00
Gravesite Disinterment	\$1,050.00	\$1,500.00	\$1,500.00	\$1,500.00	\$1,800.00
Flat Marker Installation (free for veterans)				\$50.00	\$50.00
Main Street Streetlight Banner Installation	\$25.00/banner	\$30.00/banner	\$30.00/banner	\$30.00/banner	\$30.00/banner

WATER DEPARTMENT								
Meter Size	Adopted FY2022-23		Adopted FY2023-24		Adopted FY2024-25		Proposed FY2025-26	
	Quarterly Base Charge	Flow Charge per 1000 Cubic Feet of Water Used	Quarterly Base Charge	Flow Charge per 1000 Cubic Feet of Water Used	Quarterly Base Charge	Flow Charge per 1000 Cubic Feet of Water Used	Quarterly Base Charge	Flow Charge per 1000 Cubic Feet of Water Used
5/8"	\$72.00	\$43.56	\$76.00	\$46.17	\$76.00	\$47.10	\$76.00	\$50.40
3/4"	\$72.00	\$43.56	\$80.00	\$46.17	\$89.00	\$47.10	\$98.00	\$50.40
1"	\$72.00	\$43.56	\$80.00	\$46.17	\$102.00	\$47.10	\$124.00	\$50.40
1 1/2"	\$72.00	\$43.56	\$80.00	\$46.17	\$123.00	\$47.10	\$166.00	\$50.40
2"	\$112.00	\$43.56	\$125.00	\$46.17	\$246.00	\$47.10	\$367.00	\$50.40
3"	\$202.00	\$43.56	\$225.00	\$46.17	\$454.00	\$47.10	\$683.00	\$50.40
4"	\$351.00	\$43.56	\$390.00	\$46.17	\$893.00	\$47.10	\$1,396.00	\$50.40
6"	\$718.00	\$43.56	\$790.00	\$46.17	\$2,295.00	\$47.10	\$3,800.00	\$50.40
Average Annual Domestic Bill (185 gallons/day)		\$680.00		\$680.27		\$728.00		\$758.00
		<u>Adopted</u> <u>FY2022-23</u>		<u>Adopted</u> <u>FY2023-24</u>		<u>Adopted</u> <u>FY2024-25</u>		<u>Proposed</u> <u>FY2025-26</u>
Private Fire Suppression Rates: applicable only to those private hydrants on properties not already paying Fire District Taxes		\$2,639.08		\$2,796.37		\$2,936.19		\$3,142.00
Hose Outlet (each):		\$7.04		\$7.46		\$7.83		\$8.00
Sprinkler (per nozzle):		\$1.38		\$1.46		\$1.53		\$2.00
Hydrant - Flow Test: Flow test between November 15th and April 15th at Town's discretion, not done during semi-annual flushing		\$275.00/test		\$300.00/test		\$300.00/test		\$325.00/test
Hydrant Meter - will be assessed a base charge, which includes the first 100 CF, plus actual water usage. Base charge shall be paid up front		\$590.00 plus flow charge		\$625.00 plus flow charge		\$635.00 plus flow charge		\$650.00 plus flow charge
Commercial Emergency Call-In		\$170.00		\$180.00		\$190.00		\$200.00
Residential (Single Family Home) Emergency Call-In: There is no charge for the first call-in; subsequent call-in charge is billed as shown		\$140.00 (no charge for the first call-in)		\$145.00 (no charge for the first call-in)		\$145.00 (no charge for the first call-in)		\$150.00 (no charge for the first call-in)
Final Reading		\$45.00		\$50.00		\$50.00		\$55.00
Out-of-Cycle Reading		\$90.00		\$90.00		\$90.00		\$95.00
Water On/Off (Flat fee to be assessed for each action)		\$45.00		\$50.00		\$55.00		\$60.00
Backflow Device (Testable units only)								
Initial inspection and testing:		\$90.00		\$95.00		\$100.00		\$105.00
Backflow Device repair/replacement -at cost of materials, any subcontracted costs and administrative fee				\$35.00 Administrative coordination fee + pass through costs		\$35.00 Administrative coordination fee + pass through costs		\$40.00 Administrative coordination fee + pass through costs
Inspection (per hour)		\$90.00		\$95.00		\$95.00		\$100.00
Connection Fee for Hanover Water System: The Connection/Increase in Flow Fee includes (1) a fixed fee of \$200.00 to cover admin costs and up to one Inspection and (2) a Recapture Fee assessed on GPD (Gallons per Day as determined in the Sewer Recapture Fee table). Meters and setters will be charged at cost.		\$250.00 + \$2.95/ GPD plus Meter and Setters at-cost		\$250.00 + \$3.15/GPD + pass though costs		\$250.00 + \$3.46/GPD + pass though costs		\$250.00 + \$3.82/GPD + pass though costs
Water Connection Tie-In Fee includes tap only, 3/4" and 1"		\$290.00		\$320.00		\$336.00		\$360.00
Water Connection Tie-In Fee includes tap only, 2" saddle tap		\$525.00		\$575.00		\$603.75		\$645.00
Water Connection Tie-In Fee includes tap only, 4" and larger		\$800.00		\$880.00		\$924.00		\$990.00

SEWER DEPARTMENT									
Base Capacity Charge plus Flow Charge		Adopted FY2022-23		Adopted FY2023-24		Adopted FY2024-25		Proposed FY2025-26	
Meter Size*	Quarterly Base Capacity Charge	Flow Charge per 1000 Cubic Feet of Water Used - See Below**	Quarterly Base Capacity Charge	Flow Charge per 1000 Cubic Feet of Water Used - See Below**	Quarterly Base Capacity Charge	Flow Charge per 1000 Cubic Feet of Water Used - See Below**	Quarterly Base Capacity Charge	Flow Charge per 1000 Cubic Feet of Water Used - See Below**	
5/8"	\$30.00	varies	\$31.56	varies	\$33.14	varies	\$35.50	varies	
3/4"	\$78.62	varies	\$82.71	varies	\$86.85	varies	\$93.00	varies	
1"	\$206.90	varies	\$217.66	varies	\$228.54	varies	\$245.00	varies	
1 1/2"	\$414.83	varies	\$436.40	varies	\$458.22	varies	\$490.00	varies	
2"	\$664.15	varies	\$698.69	varies	\$733.62	varies	\$785.00	varies	
3"	\$1,563.13	varies	\$1,644.41	varies	\$1,726.63	varies	\$1,847.00	varies	
4"	\$2,477.63	varies	\$2,606.47	varies	\$2,736.79	varies	\$2,928.00	varies	
6"	\$14,650.59	varies	\$15,412.42	varies	\$16,183.04	varies	\$17,316.00	varies	
Average Annual Domestic Bill (185 gallons/day)		\$475.00		\$500.00		\$525.00		\$561.00	
Unmetered Sewer Accounts - Include 25% Surcharge Above Average Annual Domestic Bill		\$593.75		\$624.63		not allowed		not allowed	
* Meter Size: Meter Size is generally determined by fixture count.									
** Sewer Flow Charge per 1000 Cubic Feet of Water Used -- Flow & Strength Charge per 1000 CF (kcf):									
Category A BOD/TSS < 250 mg/l (most residential accounts)	\$39.45	per kcf	\$41.50	per kcf	\$43.58	per kcf	\$46.60	per kcf	
Category B BOD/TSS > 250 < 400 mg/l	\$44.45	per kcf	\$46.76	per kcf	\$49.10	per kcf	\$52.50	per kcf	
Category C BOD/TSS > 400 mg/l	\$49.64	per kcf	\$52.22	per kcf	\$54.83	per kcf	\$58.70	per kcf	
<i>Category C includes all facilities with BOD and/or TSS > 400 mg/l and All Food Preparation Establishments without Approved Automated Grease Removal Systems</i>									
City of Lebanon - Base Capacity Charge		Adopted FY2022-23		Adopted FY2023-24		Adopted FY2024-25		Proposed FY2025-26	
Meter Size*	Quarterly Base Capacity Charge	Flow Charge per 1000 Cubic Feet of Water Used - See Below**	Quarterly Base Capacity Charge	Flow Charge per 1000 Cubic Feet of Water Used - See Below**	Quarterly Base Capacity Charge	Flow Charge per 1000 Cubic Feet of Water Used - See Below**	Quarterly Base Capacity Charge	Flow Charge per 1000 Cubic Feet of Water Used - See Below**	
5/8"	\$31.67	varies	\$33.32	varies	\$34.99	varies	\$37.40	varies	
3/4"	\$84.44	varies	\$88.83	varies	\$93.27	varies	\$100.00	varies	
1"	\$226.93	varies	\$238.73	varies	\$250.67	varies	\$268.00	varies	
1 1/2"	\$452.81	varies	\$476.36	varies	\$500.18	varies	\$535.00	varies	
2"	\$709.30	varies	\$746.18	varies	\$783.49	varies	\$838.00	varies	
3"	\$1,680.36	varies	\$1,767.74	varies	\$1,856.13	varies	\$1,986.00	varies	
4"	\$2,625.03	varies	\$2,761.53	varies	\$2,899.61	varies	\$3,103.00	varies	
6"	\$15,871.55	varies	\$16,696.87	varies	\$17,531.71	varies	\$18,759.00	varies	
** Sewer Flow Charge per 1000 Cubic Feet of Water Used -- Flow & Strength Charge per 1000 CF (kcf):									
Category A BOD/TSS < 250 mg/l (most residential accounts)	\$40.25	per kcf	\$42.34	per kcf	\$44.46	per kcf	\$47.60	per kcf	
Category B BOD/TSS > 250 < 400 mg/l	\$45.35	per kcf	\$47.71	per kcf	\$50.10	per kcf	\$53.60	per kcf	
Category C BOD/TSS > 400 mg/l	\$50.64	per kcf	\$53.27	per kcf	\$55.93	per kcf	\$59.80	per kcf	
<i>Category C includes all facilities with BOD and/or TSS > 400 mg/l and All Food Preparation Establishments without Approved Automated Grease Removal Systems</i>									

Industrial Discharge Permit and Septage Disposal							
		<u>Adopted FY2022-23</u>		<u>Adopted FY2023-24</u>		<u>Adopted FY2024-25</u>	<u>Proposed FY2025-26</u>
Industrial Discharge Permit Application:							
Class 1:		\$595.00		\$625.00		\$660.00	\$700.00
Class 2:		\$315.00		\$331.00		\$350.00	\$375.00
Class 3:		\$80.00		\$84.00		\$90.00	\$95.00
Septage - Tipping Fee for Residents (fee is per 1,000 gallons)		\$130.00		\$136.00		\$150.00	\$165.00
Septage - Tipping Fee for Non-Residents (fee is per 1,000 gallons)		\$155.00		\$163.00		\$180.00	\$200.00
Septage - Tipping Fee for Non-Residents from Towns who have banned Land Application of Sludge (fee is per 1,000 gallons)		\$320.00		\$336.00		\$360.00	\$400.00
Holding Tank with BOD/TSS < 400 mg/l. > 400 mg/l will be considered Septage		\$80.00		\$84.00		\$90.00	\$100.00
Sewer Connection Fees							
		<u>Adopted FY2022-23</u>		<u>Adopted FY2023-24</u>		<u>Adopted FY2024-25</u>	<u>Proposed FY2025-26</u>
Connection Fee for Hanover Sewer System – Includes Basic Fee of \$200.00 to Cover one Inspection and a Recapture Fee rate assessed on GPD (Gallons per Day as determined below)		\$250.00 + \$4.90/ gallon of GPD		\$250.00 + \$5.14/gallon of GPD		\$250.00 + \$4.63/gallon of GPD	\$250.00 + \$3.82/gallon of GPD
Sewer Connection Tie-In Fee		\$1,600.00		\$1,685.00		\$1,700.00	\$1,750.00
Deduct Meter Reading							
				<u>Adopted FY2023-24</u>		<u>Adopted FY2024-25</u>	<u>Proposed FY2025-26</u>
Deduct Meter reading (per location per billing period)				\$25.00		\$40.00	\$50.00
Recapture Fee Table							
The Recapture Fee will be determined by multiplying the peak day flow in gallons by the GPD rate above. The following are flows which shall be used to determine the peak day flow from a sewer connection:							
	GPD	Units	Category				
Apartments: Studio (one bedroom)	225		A				
Apartments: Per Bedroom	150	bedroom	A				
Athletic Facilities including Gyms and Stadiums: Participant	15	person	A				
Athletic Facilities including Gyms and Stadiums: Classroom	15	seat	A				
Athletic Facilities including Gyms and Stadiums: Spectator	3	seat	A				
Bar / Lounge	20	seat	B				
Bed & Breakfast	60	bedroom	B				
Camps: Campground w/comfort station	25	site	A				
Camps: Recreation Trailers	90	site	A				
Camps: Construction Sites	50	site	A				
Camps: Day Camp - no meals	15	site	A				
Camps: Resort Camp (night & day) limited plumbing	50	person	A				
Camps: Dining Facility only	25	person	B				
Catering & Dining Facilities	12	patron	B				
Church: Sanctuary	5	seat	A				
Country Club: Dining Room	10	seat	B				
Country Club: Snack Bar	10	seat	B				
Country Club: Locker and Showers	20	locker	A				
Dentists: Chair	200	each	A				
Dentists: Staff	35	employee	A				
Doctor's Office: Patient	10	each	A				
Doctor's Office: Staff	35	employee	A				
Dog Kennels	50	kennel	B				
Dwellings: (two bedroom minimum)	150	bedroom	A				
Dwellings: Rooming House with meals	60	bedroom	B				
Dwellings: Rooming House without meals	40	bedroom	A				
Factories (excl industrial waste): Light industry w/o cafeteria or showers	20	employee	A				
Factories (excl industrial waste): Light industry with cafeteria no showers	25	employee	B				
Factories (excl industrial waste): Light industry with cafeteria and showers	35	employee	B				
Factories (excl industrial waste): Warehouse	35	employee	A				
Factories (excl industrial waste): Assembly	20	employee	A				
Factories (excl industrial waste): Research Facilities to be determined			B				
Floor Drains NOT ALLOWED							
Fraternities & Sororities	150	bed	B				
Hairdressers: Chair	150	each	A				
Hairdressers: Staff	35	employee	A				
Hospital: Bed	250	bed	B				
Outpatient surgery: Bed	200	bed	B				

Town of Hanover Schedule of Rates and Fees for FY2026 (July 1, 2025-June 30, 2026)

Hotel & Motel: single bed*	100	bed	A					
Hotel & Motel: double bed*	200	bed	A					
*with food services category B								
Laundromats, coin operated	500	machine	B					
Maintenance Facility to be determined			B					
Nursing Homes & Assisted Living Facilities	125	bed	B					
Office Building: without cafeteria	15	employee	A					
Office Building: with cafeteria	20	employee	B					
Office Building: Unspecified Office Space	15	100 SF	A					
Picnic Parks: Bathroom only	5	person	A					
Picnic Parks: Bath house, showers and toilets	10	person	A					
Restaurant or Cafeteria: Eat-in with bathroom and kitchen waste	40	seat	B					
Restaurant or Cafeteria: Eat-in paper service, plus toilet and kitchen waste	20	seat	B					
Restaurant or Cafeteria: Kitchen waste only	3	seat	B					
Restaurant or Cafeteria: Seasonal Outdoor seating	20	seat	B					
Bars and lounges	20	seat	B					
Bars and lounges	35	employee	A					
Function Rooms	12	seat	B					
Schools:								
Boarding	100	bed	B					
Day Care & Nursery	15	person	A					
Day, without gym, cafeteria or showers	15	person	A					
Day, without gym, showers with cafeteria	20	person	B					
Day, with gyms, showers and cafeteria	35	person	B					
Post Secondary School / Classroom	15	seat	A					
Post Secondary School / Dormitory	85	bed	A					
Post Secondary School / Dormitory with Cafeteria	125	bed	B					
Service Stations	10	vehicle	B					
Shopping Centers/Grocery/Convenience stores: Large Dry Goods	5	100 SF	A					
Garbage Grinder are NOT ALLOWED								
Shopping Centers/Grocery/Convenience stores: With meat dept. w/o garbage grinder	11	100 SF	B					
Shopping Centers/Grocery/Convenience stores: with deli	3	meal	B					
Small Dry Goods	100	each	A					
	3	meal	B					
Swimming Pools	1000	800 SF	A					
Tennis Courts	250	per court	A					
Theatres	5	seat	A					
Workers: Construction bathroom only	5	employee	A					
Uses not listed will be determined from previous metered usage corrected for strength and a multiplied by a peaking factor of 2 and shall be approved by the Director of Public Works.								
Category C includes all facilities with BOD and/or TSS > 400 mg/l and All Food Preparation Establishments without Approved Automated Grease Removal Systems.								
Food grinding is prohibited – period – if discovered, a notice to cease the activity within 30 days, or penalties of \$150.00/day shall be instituted. A reoccurrence will be charged \$500.00, and then disconnection of service.								
Discharges of Fats Oil and Grease (F.O.G.) above 250 mg/L shall be assessed any line flushing charges. Any blockages or Sanitary Sewer Overflow's (SSO) attributed to F.O.G. shall warrant the discharger to be charged for all cleanup and administrative costs as well as an impact fee of \$500.00, with disconnection of service after 2 occurrences.								

TOWN *of* HANOVER

TO: Selectboard
FROM: Robert Houseman, Town Manager
DATE: May 29, 2025
SUBJECT: **Monthly Town Manager's Update**

Finance

Training:

- Tom Grantham will attend the Municipal Trustees Training Workshop on June 17th.

Projects, Programs, Studies, and Reports:

- The month of May was focused on Town Meeting preparations and follow-up reporting.
- Completed submission of materials for the Tax Recommitment Audit required when the Town has a transition of Tax Collector; audit report expected within two weeks.
- Currently preparing for FY2025 Year End, scheduling meetings with each department to discuss YTD status and possible encumbrance items.
- Initial FY2025 audit onsite work will be July 16th with audit fieldwork scheduled for the week of September 22nd.
- Completed application process for New Hampshire Municipal Bond Bank sale to fund purchase of new Fire Engine, delivered on May 20th. The bond was approved for \$1.2 million in May 2023; final cost of the engine was \$1.06 million.

Howe Library

Staffing Updates:

- The Howe Corporation's Development employee has submitted their two weeks' notice and accepted another position. I'll be taking on their responsibilities until the role is filled.

Trainings:

- April 24th-Tessa Johnson, Collections Manager attended NHMA Local Official Workshop
- April 10th-Tessa Johnson, Peter Appleton, Amelia Talbert attended (online) Library Journal Inclusive Cataloging workshop
- May 2nd-Kim Baker, Teen Librarian attended (online) Youth Services: How to Build Relationships, Programs, and Engagement
- May 23rd- Kim Baker, Teen Librarian and Brittany Blomquist, Youth Services assistant attended Hosting Fate Core Role-Playing Games at Your Library

Projects, Programs, Studies, and Reports:

- Summer reading programming has been finalized and scheduled. Summer reading brochures and t-shirts have gone out to print and will be ready for school and community distribution June 1st.
- April 30th The Art of Reciprocity: Rekindling the Exchange of Wild Affection In-Person / Hybrid program. Susie O'Keeffe discussed the four fundamental practices of the reciprocal relationship with the natural world.
- On May 9th Joseph Stallsmith, a longtime figure in the Upper Valley music scene, performed a lively hour touching on Appalachian, jug-band, blues, bluegrass, gospel, Cajun, folk-rock and the evolution of the 1960s folk revival into today's Americana through songs and stories.
- Spring Soiree May 17th, Howe library had its annual fundraising event. Over 100 community supporters were in attendance to celebrate and support the Howe.
- May 21st a Screening of Independent Lens' film, *Matter of Mind: My Alzheimer's* was followed by a community-drive discussion with panelists from The Memory Cafe and Dr. Flaherty from the Dartmouth Health Geriatric Center of Excellence.

Other Matters:

- Most popular library titles in April
 - Abundance by Ezra Klein and Derek Thompson Non-fiction
 - Heartwood: a novel by Amity Gaige
 - Great big beautiful life by Emily Henry
- **IMLS State and Federal Funding update from state librarian:** The New Hampshire Senate Finance Committee has voted to keep the New Hampshire State Council on the Arts—part of the Department of Natural and Cultural Resources—unfunded. Additionally, they voted to establish a state fund that can accept private and corporate donations in support of the arts, initially funding it with just \$1. As of today (May 21, 2025), the upcoming State of New Hampshire biennial budget allocates only \$1 to the arts. During the discussion, the sentiment was expressed that the council is a "want," not a "need," and that the arts could be sustained through a voluntary council, with members assuming any necessary administrative responsibilities.

Town Manager

Training:

- Attended the Primex - Risk Management Summit, training included:
 - HR topics
 - Strategies for Effective Public Engagement
 - Cybersecurity
 - Then and Now: The Rapidly Changing Employment Landscape
- Attended the annual Municipal Manager Association of NH, training included:
 - Navigating the tax deeded property process
 - Electioneering laws and Town Warrant Articles
 - ADA Title II compliance (website accessibility requirements)

Projects, Programs, Studies, and Reports:

- Issued the RFP for West Wheelock and South Main Street
- Issued the RFP for the Downtown Parking Study
- Continued working the Downtown Business Group and the Design team to finalize the design and fundraising efforts of the Ledyard Park
- Continue to work through the Design and Permitted process for the Girl Brook Multi-Use Path
- Held a 3- day intensive kick-off session of the Safe Routes for All planning with the Town's consultant, Toole Design

IT

Training:

- Micheal Hartell completed a weeklong class on Microsoft Azure and Entra ID. This software will be used to migrate to cloud services.

Projects, Programs, Studies, and Reports:

- The Dept. continues to update aging network and wireless equipment, including updating a pair of firewalls and core switch.
- Corey Stevens negotiated a new internet contract with First Light, providing twice the upload/download speed for the same price as the current contract.

Assessing

Training:

- Jerry Roberts just passed an advanced statistics course required to advance his certification level. Next week He will take the Certified NH Assessor Designation Exam.

Projects, Programs, Studies, and Reports:

- The Dept wrapped up the new construction and permitting for the past year and committed the assessments for tax billing.
- The Dept is preparing its public education and outreach program to inform taxpayers of the impending revaluation and continued work on the revaluation.

Parks and Recreation

Staffing Update:

- New Hire:
 - OST Program Specialist: Natasha Lockwood starting on 6/16
 - The Dept has filled all 21 summer seasonal positions!
- Vacancy:
 - OST Program Manager

Training:

- John Sherman and Asa Metcalf attended the VT Urban & Community Forestry Conference

Certifications:

- Steve Zelows - Level 1 Archery Instructor
- Justin Pero - Certified Youth Sport Administrator

Projects, Programs, Studies, and Reports:

- The Board of Cemetery Trustees will be reviewing the final recommendation for the updated cemetery ordinance in June with an anticipated proposal to the Selectboard this summer.
- As part of the Health Trust health and wellness program, all year-round Town of Hanover staff can now attend HPR classes and programs free of charge.
- Planning and preparation for Summer Camps and for six summer events are in full swing.
- The spring sports season is coming to an end. All teams will be done by June 13th.

Fire

Staffing Update:

- New Hire: Fire Fighter Garrett Rumrill will begin work on June 2. He will spend two weeks training on most fire department equipment before going on shift.

Training:

- Each shift will participate in live fire training at the New Hampshire Fire Academy during the second week of June. Training will be conducted with members from the Lebanon and Hartford Fire Departments and include operations such as searching off a hose line in zero visibility. This enables HFD to train with mutual aid partners on low frequency, high-risk events.
- The department will conduct two weeks of training on the new fire engine (see below) before the truck enters service.

Projects, Programs, Studies, and Reports:

- The department received the new fire engine approved at the 2023 Town Meeting.
 - Early approval allowed delivery to align with scheduled replacement and saved approximately \$200,000.
- This new engine will:
 - Replace Engine 4
 - Serve as the second-due engine out of the Hanover station
 - Feature a 1500-gallon water tank and a 1500 GPM pump (compared to the usual 1000-gal/1250 GPM)
 - Improve water delivery to areas without hydrants
- Once in service, Engine 4 will be listed for sale on an online fire apparatus auction site.
- Engine 5, previously out of service for a year, has been sold to a small department in Pennsylvania.



Police Department

Staffing:

- **Police Department/Patrol:**

- New hires (1 Police officer candidate (Omar Boone) starting in June 2025, with a September Police Academy scheduled)
- (A police officer selection process is scheduled for June 10th, with 2 applicants confirmed for our one sworn officer vacancy.)
- We currently have a new officer, Henry Htoo, in the NH Police Academy, scheduled to graduate in August 2025.
- Sergeant Dan Fowler was promoted to Lieutenant effective 5/11/2025.
- Patrolman Aaron Frank was promoted to Corporal effective 5/11/2025.
- Corporal Joe Landry was promoted to Sergeant effective 5/11/2025.
- Ofc. Ignas Pamparas completed his 12-week Field Training Officer FTO program this month and can work solo.

- **Communications Division:**

- 3 Communication Officer Vacancies
- A communication officer selection process is scheduled for June 10th, with 3 applicants confirmed. Currently there are 3 vacancies, and 2 candidates are in the background phase of the selection process.

Training:

- Sergeant Casale completed a three-day Police Officer Bike Patrol course and joined the bike patrol unit. Sgt. Casale was awarded the top bike cop award for his skills demonstrated during the course.
- Upper Valley Regional Task Force, chaired by LT Ufford, met to discuss the role of hospital emergency management and response integration during a crisis
- LT Ufford coordinated with Dartmouth Emergency Management and HFD for the upcoming active threat drill planned for July 2025.

Outreach/Education:

- On May 4th, Sergeants Swain and Casale attended a “bike rodeo” at the Ray School.
- On May 16th Chief Martin, Captain Schibuola and LT Ufford traveled to Concord to meet with the family of fallen Chief James Collins to participate in the NH Law Enforcement Memorial Ceremony.
- On May 20th LT Ufford and Corporal Alterisio participated in a lockdown drill at Hanover High School.

Projects, Programs, Studies, and Reports:

- CALEA Year 2 Accreditation preparation for assessment is underway and is currently scheduled for October 24th to November 1, 2025.

- **BIKE PATROL UNIT:** Two new bikes have arrived and are being equipped at the highway department. (1) Trek Police Mountain Bike and (2) Trek Police Mountain E-bike. These two new bikes expand our off-road capabilities/presence on Hanover's bike/jogging paths. They can be used for regular patrol; however, they are lighter and more agile.
- **Future events:** Planning a mock active shooter exercise for July 2025 at Dartmouth College with Dartmouth Safety & Security, Emergency Management, and Hanover Fire Department. Monthly meetings are underway.

Etna Library

- **Summer Reading Programs:** The Summer Reading Programs begin on June 18th, for both kids and adults. Thirteen different local businesses generously donated over \$600 worth of gift certificates for the library to award as summer reading prizes.
- **Special Summer Events:** The library has a full schedule of summer events including visits from Alyx the Magician, Naturalist Susie Spikol, Lindsay & Her Puppet Pals, VINS, and Squam Lakes Science Center.
- **June Newsletter Link:** <https://mailchi.mp/cfe1ed837432/etna-library-june-2025-newsletter-10333341>

Selectboard
May 19, 2025
DRAFT

SELECTBOARD MEETING
May 19, 2025
7PM - MUNICIPAL OFFICE BUILDING - HANOVER, NH

The meeting of the Selectboard was called to order at 7p.m. by C. Callaghan, Chair.

Also present were: Rob Houseman, Town Manager, Jennie Chamberlain, Selectboard Member, Jarett Berke, Secretary

Absent: Athos Rassias, Selectboard Member, Joanna Whitcomb, Vice Chair

1. Opening of Meeting

a. Call to Order

C. Callaghan called the meeting to order.

2. Public Hearing

None

3. Agenda Review

None

4. Announcements/recognition

None

5. Public Comment

a. Public may address the Board

Margaret Bragg, 108 Greensboro Road had hoped to end Town Meeting by remembering and honoring David Souter who had died a few days before. She referenced an article from the NY Times sharing Justice Souter's warning that ignorance of the constitution can lead to the death of democracy.

6. Business Requiring Discussion

a. Organizational meeting for 2025-2026 Selectboard

- Election of Officers
 - Chair
 - Vice Chair
 - Secretary
- Board/Committee Assignments

This item is deferred as two Selectboard members are not in attendance.

b. Statutory Boards and Committees Review

As requested, a chart of all Town Boards was included in the packet for the Boards review.

c. Request for Proposals (RFP) – review consultant services and design, cost estimation, financing strategy, and public outreach for the West Wheelock and South Main Street corridor improvements

A draft RFP was included in the meeting packet for the Boards review.

R. Houseman addressed the item. Discussion ensued about a compressed timeline and indicating that within the RFP.

d. Warrant Article 22, review and approve draft of Selectboard transmittal letter

Selectboard

May 19, 2025

“Reject any expansion of taxpayer funding for private education until we have full accountability, transparency, and a sustainable funding plan that ensures no further strain on public schools or local property taxpayers”.

A simple draft transmittal letter was included in the meeting packet for the Boards consideration.

The letter will be sent to Governor Ayotte.

e. Warrant Article 23 review

To call on the Hanover Town Manager and the Hanover Police Chief NOT to enter into or sign any agreements with Immigration and Customs Enforcement's (ICE) 287(g) program.

Note that this warrant article is nonbinding guidance. A copy of Town Ordinance 38 was included in the meeting packet. If the Selectboard would like to consider moving forward with discussions on this warrant article, R. Houseman recommends that the Senior leadership team at the Police Department, the Town Attorney, and Town Manager be given 45 days to review Article 23 and Town Ordinance 38. The focus of the review is to determine if any changes to Ordinance 38 are warranted.

f. Warrant Article 24 review

“All meetings of the Selectboard be available for remote participation, either by video or audio, in real time, through the use of appropriate technology, including but not limited to conference calls, video conferencing, or online meeting platforms. This requirement will apply to all regular and special meetings, and it will ensure that town residents have the ability to participate in Selectboard proceedings remotely”

Note that this warrant article is nonbinding guidance. If the Selectboard wishes to move in this direction, R. Houseman recommends that Staff be given 30 days to evaluate how best to transition to a hybrid meeting format.

As the discussion around Zoom webinar usage for Selectboard meetings occurred and R. Houseman noted he will reach out to JAM for information about how to best make it work, Nick from JAM, who was running the meeting, made some comments to answer questions how they run it in other towns.

7. Town Manager Monthly Report

None

C. Callaghan reviewed Town Meeting voting and elections with a staff member present.

8. Business Requiring Action

a. Recommendation to review the proposed Rate and Fee Schedule on Monday, June 2, and to Set Public Hearing on Monday, June 16, to approve the Proposed Rate and Fee Schedule for Fiscal Year 2026

At 7:29 pm J. Berke MOVED to set a Public Hearing on Monday, June 16, 2025, to review and approve the Proposed Rates and Fees. J. Chamberlain SECONDED. All in favor

b. Approval of May 5, 2025, Selectboard Minutes

At 7:34 pm J. Berke MOVED to Approve the minutes of May 5 as amended. J. Chamberlain SECONDED. All in favor

c. Approval of item i to iii Consent

Selectboard

May 19, 2025

i. Donation - Police Department

\$500.00 was donated from a member of Dartmouth College's Class of 2010 who expressed remorse for the way he treated a Hanover Police Officer when he was a student. This donation was given as a form of amends.

ii. Donation - Fire Department

2006 Chevy Silverado donated by Rob Sully for training purposes

iii. Donation - Etna Library

\$1,000.00 was donated to the Etna Library from Mr. and Mrs. Thomas P. Hall

At 7:35 pm J. Berke MOVED to Approve the consent agenda. J. Chamberlain SECONDED. All in favor

9. Selectboard Reports

- J. Berke
 - Deer Committee wishes to come to the June 2nd meeting to discuss expanding the program
 - Downtown group, heard presentation about Ledyard Park design
 - Trustees
- J. Whitcomb
 - No Report
- C. Callaghan
 - CIPC
 - Discussion about library projects and funding
 - R. Houseman gave a brief update about Ledyard Park and will prepare a presentation for a Selectboard meeting
- A. Rassias
 - No Report
- J. Chamberlain
 - Bike Walk –
 - The Town of Hanover kicked off the Shared Streets Vision Planning to create more inclusive and accessible multimodal network of streets and sidewalks for all ages and abilities. There is a survey posted along with the consultant presentation that was well attended at town hall introducing the project and possibilities on the Hanover Bike Walk website at bit.ly/hanoverstreets. The survey is also linked on the town website.
 - WaHG Trail planning for a West Lebanon and Hanover Greenway Trail to develop a connection for people walking, bicycling, rolling and other active transportation modes between Hanover and West Lebanon within the route 10 corridor has kicked off as a Stantec consultant leading a feasibility study to determine possible paths and phases along 4 sections of the corridor. Find out more about the project at wahgtrail.org
 - Hanover Bike Walk cheered students on during Bike to School Day and cosponsored a successful Bike Rodeo skills clinic with Hanover Parks and Recreation, with support from Hanover Police, where kids practiced their bicycling skills, did equipment safety checks and one learned to ride!
 - Hanover Bike Walk sponsored a coned bikeway demonstration project on Lebanon Street for Curb Your Car Day and received enthusiastic support from bicyclists and drivers that separation made this space significantly more bike friendly and was needed as otherwise drivers routinely drive in the bike lane around a blind turn.
 - Planning Board – Thanked Brian Edwards, Chair, who will be retiring from the board for his steadfast leadership, wit and charm, and long service to the town on the Planning Board.
 - Sustainable Hanover

Selectboard
May 19, 2025

- Discussed limits of Lebanon landfill if Concord passes legislation restricting landfill expansion and the importance of waste diversion and reduction, and complications from PFAS, or per- and polyfluoroalkyl substances, contaminations which makes compost at landfills restricted in use
- Meeting Wednesday, where students will present on the feasibility of micro geo-exchange serving residential clusters
- Conservation Commission

Other Business

R. Houseman made comments about the Planning Board Chair, conferences he has attended, and announced a new Town Clerk, Tracy Walsh, was sworn in today (staff member present).

10. Adjournment

The board did not need to attend a non-public session.

J. Berke MOVED to adjourn at 7:56pm. J. Chamberlain SECONDED.

All in favor. The meeting adjourned at 7:56PM.

Respectfully Submitted,

Jarett Berke, Secretary

SUMMARY

Item 8a

At 7:29 pm J. Berke MOVED to set a Public Hearing on Monday, June 16, 2025, to review and approve the Proposed Rates and Fees. J. Chamberlain SECONDED. All in favor

Item 8b

At 7:34 pm J. Berke MOVED to Approve the minutes of May 5 as amended. J. Chamberlain SECONDED. All in favor

Item 8c

At 7:35 pm J. Berke MOVED to Approve the consent agenda. J. Chamberlain SECONDED. All in favor

Item 10

J. Berke MOVED to adjourn at 7:56pm. J. Chamberlain SECONDED. All in favor.

INTEROFFICE MEMORANDUM

TO: SELECTBOARD

FROM: ELLEN BULLION

SUBJECT: AUTHORIZATION OF BONDS AND APPROVAL OF NHMBB LOAN AGREEMENT

DATE: 6/2/2025

At the May 9, 2023 Town Meeting, Article 11 was approved authorizing the Town to raise \$1.2 million through the issuance of bonds or notes for the purchase of a fire engine. The final cost of the engine was less than anticipated at \$1,060,615. After researching different options including a loan from Mascoma Bank and Bond issue through New Hampshire Municipal Bond Bank, the latter was chosen. This was discussed during the budget process and at the time the interest rate reference was the January 2025 20-year rate of 3.84%. The loan agreement for signature tonight has a not-to-exceed rate of 5.25%, the actual rate to be determined on the sale date of July 16th and may be lower. While this maximum rate is higher than the January interest rate, it remains competitive compared to the alternatives. The rate of 5.25% would result in additional expense of approximately \$7,500.00 in year one, FY2026.

Tonight, I am requesting the Selectboard vote to authorize the bonds in accordance with the Town Meeting vote and approve the loan agreement with the New Hampshire Municipal Bond Bank.

Summary of Loan Agreement:

- Loan amount - \$1,060,615
- Interest Rate – Not to exceed 5.25%
- Term – 20 Years

TOWN OF HANOVER, NEW HAMPSHIRE
(the "Issuer")

CERTIFICATE OF VOTE REGARDING AUTHORIZATION
OF BONDS AND APPROVAL OF
LOAN AGREEMENT WITH THE NEW HAMPSHIRE MUNICIPAL BOND BANK

I, the undersigned Clerk of the Issuer, hereby certify that a meeting of the Governing Board of Issuer (the "Board") was held on June 2, 2025. A quorum of the Board was in attendance and voting throughout.

I further certify that there are no vacancies on the Board, that all of the members of the Board were duly notified of the time, place and purposes of said meeting, including as one of the purposes the authorization of bonds and the approval of a Loan Agreement between the New Hampshire Municipal Bond Bank (the "Bond Bank") and the Issuer.

I further certify that the following is a true copy of resolutions unanimously adopted at said meeting:

RESOLVED: That under and pursuant to the Municipal Finance Act, Chapter 33, N.H.R.S.A., as amended, the New Hampshire Municipal Bond Bank Law, Chapter 35-A, N.H.R.S.A., as amended, and other laws in addition thereto, and to votes of the Issuer duly adopted on March 9, 2023 under Article 11 of the Warrant for such annual meeting of the Issuer there be and hereby is authorized the issuance of a \$1,060,615 Bond of the Issuer (the "Bond") which is being issued by the Issuer to finance the purchase of a fire engine.

The Bond shall be dated as of its date of issuance, shall be in such numbers and denominations as the purchaser shall request, shall mature in accordance with the schedule set forth in Exhibit A to a certain Loan Agreement hereinafter described (the "Loan Agreement"), shall bear a net interest cost rate (as defined in the Loan Agreement) of five and one quarter percent (5.25%) per annum or such lesser amount as may be determined by a majority of the Board. The Bond shall be substantially in the form set forth as Exhibit B to the Loan Agreement and otherwise shall be issued in such manner and form as the signatories shall approve by their execution thereof.

RESOLVED: That the Bond shall be sold to the Bond Bank at the par value thereof plus any applicable premium.

RESOLVED: That in order to evidence the sale of the Bond, the Treasurer of Issuer and a member of the Board are authorized and directed to execute, attest and deliver, in the name and on behalf of the Issuer, a Loan Agreement in

substantially the form submitted to this meeting, which is hereby approved, with such changes therein not inconsistent with this vote and approved by the officers executing the same on behalf of the Issuer. The approval of such changes by said officers shall be conclusively evidenced by the execution of the Loan Agreement by such officers.

RESOLVED: That all things heretofore done and all action heretofore taken by the Issuer and its officers and agents in its authorization of the project to be financed by the Bond are hereby ratified, approved and confirmed.

RESOLVED: That the Clerk and the signers of the Bond are each hereby authorized to take any and all action necessary and convenient to carry out the provisions of this vote, including delivering the Bond against payment therefor.

RESOLVED: That the useful life of the project being financed is in excess of twenty (20) years.

I further certify that said meeting was open to the public; the aforesaid vote was not taken by secret ballot nor in executive session; that notice of the time and place of said meeting was posted in at least two (2) appropriate public places within the territorial limits of the Issuer, or published in a newspaper of general circulation in said area, at least twenty-four (24) hours, excluding Sundays and legal holidays, before said meeting; that no deliberations or actions with respect to the vote were taken in executive session; and that the minutes of said meeting have been promptly recorded and have been or will be made open to inspection not more than five (5) business days after the meeting, all in accordance with Chapter 91-A, N.H.R.S.A., as amended.

I further certify that the above vote has not been amended or rescinded and remains in full force and effect as of this date.

WITNESS my hand and seal of the Issuer this ____ day of _____, 2025.

CLERK OF ISSUER

(SEAL)

=====

L O A N A G R E E M E N T

=====

AGREEMENT, dated the 16th day of July, 2025 between the New Hampshire Municipal Bond Bank, a public body corporate and politic constituted as an instrumentality of the State of New Hampshire exercising public and essential governmental functions (hereinafter referred to as the "Bank"), created pursuant to the provisions of Chapter 35-A of the New Hampshire Revised Statutes Annotated, as amended (hereinafter referred to as the "Act"), having its principal place of business in Concord, New Hampshire, and **Town of Hanover** (hereinafter referred to as the "Governmental Unit"):

W I T N E S S E T H :

WHEREAS, pursuant to the Act, the Bank is authorized to loan money (hereinafter referred to as the "Loans") to the Governmental Unit and the Governmental Unit is authorized to contract with the Bank with respect to such Loans to be evidenced by its municipal bonds (as defined in the Act) to be purchased by the Bank; and

WHEREAS, the Governmental Unit has requested a loan from the Bank in the amount of **\$1,060,615** (hereinafter referred to as the "Loan") and, to evidence the indebtedness to be incurred thereby, has duly authorized the issuance of its bonds in at least that principal amount (the "Municipal Bonds"), which Municipal Bonds are to be purchased by the Bank in accordance with this Loan Agreement; and

WHEREAS, the Bank has adopted or will adopt a General Bond Resolution (hereinafter referred to as the "Bond Resolution") authorizing the issuance of its bonds from time to time, a portion of the proceeds of which will be expended for the purpose of making the Loan, and will adopt a resolution authorizing the making of the Loan to the Governmental Unit by the purchase of the Municipal Bonds,

NOW, THEREFORE, the parties agree:

1. The following words or terms used herein shall have the following meanings:

(a) "Fees and Charges" shall mean all fees and charges authorized to be charged by the Bank for the use of its services or facilities pursuant to paragraph VIII of Section 6 of the Act.

(b) "Governmental Unit's Allocable Proportion" shall mean the proportionate amount of the total requirement in respect of which the term is used, determined by the ratio that the Loan then outstanding bears to the total of all Loans which are then outstanding, as certified by the Bank.

(c) "Loan Obligation" shall mean that amount of bonds issued by the Bank which is equal to the principal amount of the Municipal Bonds outstanding.

(d) "Maximum Interest Cost Rate" shall mean an interest cost rate 5.250% per centum per annum.

(e) "Municipal Bonds Interest Payments" shall mean the amount to be paid by the Governmental Unit pursuant to this Loan Agreement representing interest due or to become due on its Municipal Bonds.

(f) "Municipal Bonds Principal Payments" shall mean the amount to be paid by the Governmental Unit pursuant to this Loan Agreement representing principal due or to become due on its Municipal Bonds.

2. The Bank hereby agrees to make the Loan and the Governmental Unit hereby agrees to accept the Loan and to sell to the Bank the Municipal Bonds in the principal amount of the Loan. The Municipal Bonds shall bear interest from the date of their delivery to the Bank at such rate or rates per annum as will result in an interest cost rate to the Governmental Unit of the Maximum Interest Cost Rate (as calculated by the "Interest Cost Per Annum" method) or at rates per annum as will result in a lesser interest cost rate to the Governmental Unit as determined by the Bank. The interest cost rate for purposes of this Loan Agreement will be computed as if the Municipal Bonds bore interest from the delivery date of the Bank's bonds, and without regard to Sections 4 and 5 hereof which require that Governmental Unit make funds available to the Bank for the payment of principal and interest at least thirty (30) calendar days (inclusive of Saturdays, Sundays and holidays) prior to each respective principal and interest payment date. Subject to any applicable legal limitations, the rate or rates of interest borne by the Municipal Bonds shall be not less than the rate or rates of interest borne by the bonds issued by the Bank (for corresponding maturities) the proceeds of sale of which were used to make the Loan and to purchase the Municipal Bonds. Notwithstanding the above, the obligation of the Bank to make the Loan shall be conditioned upon receipt by the Bank of the proceeds of bonds issued by the Bank both for the purposes set forth herein and to create the reserves required by the Bond Resolution.

3. The Governmental Unit has duly adopted or will adopt all necessary votes and resolutions and has taken or will take all proceedings required by law to enable it to enter into this Loan Agreement and issue its Municipal Bonds for purchase by the Bank.

4. The Municipal Bonds Interest Payments shall be not less than the total amount of interest the Bank is required to pay on the Loan Obligation and shall be scheduled by the Bank in such manner and at such times as to provide funds sufficient to pay interest as the same becomes due on the Loan Obligation and the Governmental Unit shall make such funds available to the Bank at least thirty (30) calendar days (inclusive of Saturdays, Sundays and holidays) prior to each interest payment date.

5. The Municipal Bonds Principal Payments shall be scheduled by the Bank in such manner and at such times as to provide funds sufficient to pay the principal of the Loan Obligation as the same matures (based upon the maturity schedule provided by and for the Governmental Unit and appended hereto as Exhibit A) and the Governmental Unit shall make such funds available to the Bank at least thirty (30) calendar days (inclusive of Saturdays, Sundays and holidays) prior to each principal payment date.

6. The Governmental Unit agrees to be obligated to pay Fees and Charges to the Bank. Such Fees and Charges, if any, collected from the Governmental Unit shall be in an amount sufficient, together with the Governmental Unit's Allocable Proportion of other monies available therefore, including any grants made by the United States of America or any agency or instrumentality thereof or by the State or any agency or instrumentality thereof, to pay on a semi-annual basis:

(a) as the same becomes due, the Governmental Unit's Allocable Proportion of the administrative expenses of the Bank; and

(b) as the same becomes due, the Governmental Unit's Allocable Proportion of the fees and expenses of the trustee and paying agents for the bonds of the Bank.

7. The Governmental Unit agrees to be obligated to make the Municipal Bonds Principal Payments scheduled by the Bank on an annual basis and agrees to be obligated to make the Municipal Bonds Interest Payments scheduled by the Bank and to pay any Fees and Charges imposed by the Bank on a semi-annual basis. All Municipal Bonds Principal Payments, Municipal Bonds Interest Payments and Fees and Charges shall be payable only by means of wire transfer or automated clearinghouse funds (ACH).

8. The Governmental Unit agrees that any loan agreements previously entered into between the Bank and the Governmental Unit with respect loan obligations previously undertaken and presently outstanding between the Bank and the Governmental Unit, are hereby amended as follows:

Payments on account of any municipal bonds interest payments and any municipal bonds principal payments shall be made to the Bank at least thirty (30) calendar days (inclusive of Saturdays, Sundays and holidays) prior to each municipal bond interest or principal payment date pertaining thereto. All such payments shall be made only by wire transfer or automated clearinghouse funds(ACH).

9. The Bank shall not sell and the Governmental Unit shall not redeem prior to maturity any of the Municipal Bonds with respect to which the Loan is made by the Bank prior to the date on which all outstanding bonds issued by the Bank with respect to such Loan are redeemable, and in the event of any sale or redemption prior to maturity of such Municipal Bonds thereafter, the same shall be in an amount equal to the aggregate of (i) the principal amount of the Loan Obligation so to be redeemed, (ii) the interest to accrue on the Loan Obligation so to be redeemed to the next redemption date thereof not previously paid, (iii) the applicable premium, if any, payable on the Loan Obligation so to be redeemed, (iv) the costs and expenses of the Bank in effecting the redemption of the Loan Obligation, and (v) at the direction of the Bank, an amount equal to the proportionate amount of bonds so to be redeemed which were issued by the Bank with respect to the Loan Obligation and necessary to fund a portion of the reserve fund authorized by Section 11 of the Act, less the amount of monies or investments available for withdrawal from such reserve fund and for application to the redemption of such bonds issued by the Bank in accordance with the terms and provisions of the Bond Resolution, as determined by the Bank; provided, however, that, in the event the Loan Obligation has been refunded and the refunding bonds issued by the Bank were issued in a principal amount in excess of or less than the Loan Obligation remaining unpaid at the date of issuance of such refunding bonds, the amount which the Governmental

Unit shall be obligated to pay under item (i) hereof shall be the amount set forth in the resolution of the Bank. In the event the Loan Obligation has been refunded and the interest the Bank is required to pay on the refunding bonds is less than the interest the Bank was required to pay on such Loan Obligation, the amount which the Governmental Unit shall be obligated to pay under item (ii) above shall be the amount of interest set forth in the resolution of the Bank. In no event shall any such sale or redemption of Municipal Bonds be affected without the prior written agreement and consent of both parties hereto.

10. Simultaneously with the delivery to the Bank of the Municipal Bonds, which Municipal Bonds shall be in a form acceptable to the Bank, the Governmental Unit shall furnish to the Bank an opinion of bond counsel satisfactory to the Bank which shall set forth among other things, the unqualified approval of said Municipal Bonds then being delivered to the Bank and that said Municipal Bonds will constitute valid general obligations of the Governmental Unit as required by the Act. The Governmental Unit shall bear the cost of such opinion.

11. The Governmental Unit shall be obligated to notify the Bank and the corporate trust office of the trustee for the bonds of the Bank in writing at least 30 days prior to each interest payment date of the name of the official of the Governmental Unit to whom invoices for the payment of interest and principal should be addressed.

12. The Governmental Unit and the Bank agree that the Municipal Bonds Principal Payments, the Municipal Bonds Interest Payments and the Municipal Bonds or a portion thereof may be pledged or assigned by the Bank under and pursuant to the Bond Resolution.

13. The Governmental Unit agrees upon surrender to it of the Municipal Bonds by the Bank it will, at the option of the Bank, cause there to be delivered to the Bank either registered or coupon Municipal Bonds as the case may be.

14. Prior to payment of the amount of the Loan, or any portion thereof, and the delivery of the Governmental Unit's Municipal Bonds to the Bank or its designee, the Bank shall have the right to cancel all or any part of its obligations hereunder if:

(a) any representation made by the Governmental Unit to the Bank in connection with application for Bank assistance shall be incorrect or incomplete in any material respect; or

(b) the Governmental Unit has violated commitments made by it in its application and supporting document or has violated any of the terms of this Loan Agreement.

15. (a). The Governmental Unit agrees to furnish to the Bank annually as long as any of the Municipal Bonds remain outstanding such financial reports, audit reports and other financial information as the Bank may reasonably require.

(b). So long as the Governmental Unit shall constitute an obligated person within the meaning of S.E.C. Rule 15c2-12 (the "Rule") as in effect from time to time, the Governmental Unit agrees to furnish to the Bank (1) such financial information and operating data with respect to the Governmental Unit at such times and in such forms as the Bank shall

reasonably request in order to comply with the provisions of the Rule, (2) when and if available, the Governmental Unit agrees promptly to provide the Bank with its audited financial statements for each fiscal year and (3) the Governmental Unit agrees to provide to the Bank in a timely manner, notice of any of the following events with respect to the Municipal Bonds, if material:

- (a) Principal and interest payment delinquencies.
- (b) Non-payment related defaults, if material.
- (c) Unscheduled draws on debt service reserves reflecting financial difficulties.
- (d) Unscheduled draws on credit enhancements reflecting financial difficulties.
- (e) Substitution of credit or liquidity providers, or their failure to perform.
- (f) Adverse tax opinions, the issuance by the Internal Revenue Service of proposed or final determinations of taxability, Notices of Proposed Issue (IRS Form 5701-TEB) or other material notices or determinations with respect to the tax status of the Municipal Bonds, or other material events affecting the tax-exempt status of the Municipal Bonds.
- (g) Modifications to rights of the beneficial owners of the Municipal Bonds, if material.
- (h) Bond calls, if material, and tender offers.
- (i) Defeasance of the Municipal Bonds or any portion thereof.
- (j) Release, substitution or sale of property securing repayment of the Municipal Bonds, if material.
- (k) Rating changes.
- (l) Bankruptcy, insolvency, receivership or similar event of the Government Unit.
- (m) The consummation of a merger, consolidation, or acquisition involving the Government Unit or the sale of all or substantially all of the assets of the Government Unit, other than in the ordinary course of business, the entry into a definitive agreement to undertake such an action or the termination of a definitive agreement relating to any such actions, other than pursuant to its terms, if material.
- (n) Appointment of a successor or additional trustee or the change of name of a trustee, if material.
- (o) Incurrence of a financial obligation of the Obligated Person, if material, or agreement to covenants, events of default, remedies, priority rights, or other similar terms of a financial obligation of the Obligated Person, any of which affect Owners of the Notes, if material; and
- (p) Default, event of acceleration, termination event, modification of terms, or other similar events under the terms of a financial obligation of the Obligated Person, any of which reflect financial difficulties.

The Governmental Unit agrees that from time to time it will also provide notice to the Bank of the occurrence of other events, in addition to those listed above, if such other event is material with respect to the Municipal Bonds.

The Governmental Unit will provide, in a timely manner, to the Bank, notice of a failure to satisfy the requirements of this Section.

The intent of the Governmental Unit's undertaking pursuant to this Section is to facilitate the Bank's ability to comply with the requirements of the Rule. Accordingly, the Governmental Unit agrees to provide the Bank with any additional information the Bank may reasonably require in order to comply with the requirements of the Rule, as in effect from time to time.

To the extent the Rule no longer requires issuers of municipal securities to provide all or any portion of the information the Governmental Unit has agreed to provide pursuant to this Section, the obligation of the Governmental Unit to provide such information pursuant to this Section also shall cease immediately.

The sole remedy available to the Bank or to any other person for the failure of the Governmental Unit to comply with any provision of this Section shall be an action for specific performance of the Governmental Unit's obligations under this Section.

16. The Governmental Unit shall not take, or permit to be taken, any action or actions that would cause any Municipal Bond to be an "arbitrage bond" within the meaning of Section 148 of the Internal Revenue Code of 1986, as from time to time in effect (the "Code") or a "private activity bond" within the meaning of Section 141(a) of the Code or that would cause any Municipal Bond to be "federally guaranteed" within the meaning of Section 149(b) of the Code, or that would otherwise cause interest on the Municipal Bonds to become included in gross income of the recipient thereof for the purpose of federal income taxation.

The Governmental Unit shall at all times do and perform all acts and things permitted by law and necessary or desirable in order to assure that interest paid by the Governmental Unit on the Municipal Bonds shall be excluded from gross income of the recipient thereof for the purpose of federal income taxation under any valid provision of law and to assure that the Municipal Bonds shall not be "private activity bonds" within the meaning of Section 141(a) of the Code, including the preparation and filing of any statements required to be filed by the Governmental Unit in order to maintain such exclusion.

17. If any provision of this Loan Agreement shall for any reason be held to be invalid or unenforceable, the invalidity or unenforceability of such provision shall not affect any of the remaining provisions of this Loan Agreement and this Loan Agreement shall be construed and enforced as if such invalid or unenforceable provision had not been contained herein.

18. This Loan Agreement may be executed in one or more counterparts, any of which shall be regarded for all purposes as an original and all of which constitute but one and the same instrument. Each party agrees that it will execute any and all documents or other instruments, and take such other actions as may be necessary to give effect to the terms of this Loan Agreement.

19. No waiver by either party of any term or conditions of this Loan Agreement shall be deemed or construed as a waiver of any other terms or conditions, nor shall a waiver of any breach be deemed to constitute a waiver of any subsequent breach, whether of the same or of a different section, subsection, paragraph, clause, phrase, or other provision of this Loan Agreement.

20. This Loan Agreement merges and supersedes all prior negotiations, representations, and agreements between the parties hereto relating to the subject matter hereof and constitutes the entire agreement between the parties hereto in respect hereof.

IN WITNESS WHEREOF, the parties hereto have executed this agreement the day and year first above written.

NEW HAMPSHIRE MUNICIPAL BOND BANK

Attest:

By _____
Secretary, NHMBB

(NHMBB SEAL)

By _____
Chairman, NHMBB Board of Directors

Attest:

By _____
Member, Board of Selectmen

By _____
Town Clerk

By _____
Town Treasurer

**(Town
SEAL)**

EXHIBIT B

No. R-1

\$ _____

STATE OF NEW HAMPSHIRE
TOWN OF HANOVER

\$ _____ GENERAL OBLIGATION BOND

The Town of Hanover (hereinafter called the "Issuer") in the State of New Hampshire promises to pay to U.S. Bank Trust Company, National Association, as Trustee for the New Hampshire Municipal Bond Bank, or registered assigns, the sum of _____ Dollars (\$ _____) in installments on August 15 of each year as set forth below, with interest on each installment at the rate per annum set forth below opposite the year in which the installment becomes due:

<u>Year</u>	<u>Installments</u>	<u>Interest Rate</u>
2026		
2027		
2028		
2029		
2030		
2031		
2032		
2033		
2034		
2035		
2036		
2037		
2038		
2039		
2040		
2042		
2043		
2044		

The interest rate on each installment shall run from the date of the original delivery of this Bond to the New Hampshire Municipal Bond Bank and payment therefor and until payment of such installment, and such interest shall be payable semiannually on February 15 and August 15 of each year, beginning February 15, 2026. Both principal and interest on this Bond are payable at U.S. Bank Trust Company, National Association, 60 Livingston Avenue, St. Paul, MN 55107, or at its successor as Trustee under the General Bond Resolution of the New Hampshire Municipal Bond Bank. Final payment of the interest and principal of this Bond shall be

made upon surrender of this Bond for cancellation at the bank or trust company at which this Bond is then payable.

This Bond is the only instrument representing a borrowing of \$_____ issued by the Issuer pursuant to the Municipal Finance Act, RSA 33, as amended, the New Hampshire Municipal Bond Bank Law, RSA 35-A, as amended, and other laws in addition thereto, and to votes of the Issuer duly adopted on March 9, 2023. This Bond is being issued to finance the purchase of a fire engine.

This Bond is transferable only upon presentation to the Treasurer of the Issuer with a written assignment duly acknowledged or proved. No transfer hereof shall be effectual unless made on the books of the Issuer kept by the Treasurer as transfer agent and noted hereon by the Treasurer with a record of payments as provided hereon.

IN WITNESS WHEREOF, the Issuer has caused this Bond to be signed by at least a majority of the Issuer's Governing Board and countersigned by its Treasurer and its seal to be affixed hereto, as of the 14th day of August, 2025.

Countersigned: TOWN OF HANOVER, NEW HAMPSHIRE

Treasurer

(Seal) _____
Governing Board

Certificate of Registration of Transfers

This Bond is registered in the name of the transferee noted hereon on the books of the Issuer kept by the Treasurer as transfer agent.

Name of Registered Transferee	Date of Registration of Transfer	Date Which Interest Paid	Aggregate Principal Paid	Balance of Principal Due	Signature of Treasurer
-------------------------------------	--	-----------------------------------	--------------------------------	-----------------------------------	------------------------------

MEMORANDUM

To: Town of Hanover, New Hampshire (the “Town”)
From: Renelle L. L’Huillier, Devine, Millimet & Branch, P.A. (“Bond Counsel”)
Re: Post-Issuance Tax Compliance Policies and Procedures
Date: May 16, 2025

At the closing of a tax-exempt bond or note issuance, the Town’s governing board signs a No Arbitrage and Tax Certificate. This document provides Bond Counsel with the information necessary to make a determination that the bond or note is tax exempt at the time of issuance.

However, there are a number of things that can occur “post-issuance” that could adversely affect the tax-exempt status of the bonds or notes, such as (i) the direct or indirect use of the proceeds by a non-governmental person that might cause the bonds or notes to be taxable private activity bonds; or (ii) the Town’s potential liability for rebate payments to the federal government due to the failure to expend funds quickly enough to qualify for one of the spending exceptions to the rebate rules.

Over the past few years, the Internal Revenue Service (the “IRS”) has focused on the post-issuance tax compliance of municipal bond issuers. During that time, we have seen an increased number of IRS examinations of bonds and tax notes to determine compliance with the requirements of the Internal Revenue Code of 1986, as amended (the “Code”). One of the questions posed by the IRS in such examinations is whether the issuer has adopted written procedures to ensure compliance with the Code provisions applicable to tax-exempt bonds and notes.

In addition, the IRS includes guidance on its website that makes it evident that written procedures are an important part of an issuer’s tax-exempt bond program. Moreover, in the fall of 2011, the IRS updated its Form 8038-G to add questions about whether the issuer has established written procedures to address private activity concerns and to monitor the requirements of section 148 related to arbitrage rebate. The IRS also now requests more detail about an issuer’s reimbursement for pre-issuance expenditures on this form.

In order to address this increased level of review by the IRS, we have prepared a form of Post-Issuance Tax Compliance Policies and Procedures. This form of policy names a “Coordinator” who has the responsibility to monitor compliance with the policy. It follows the requirements of the Code and closely tracks the information included in the No Arbitrage and Tax Certificate that is signed at the closing of a bond or tax note financing.

We have also included a form of resolution that the governing board may pass in order to adopt this formal policy.

As the Town is planning to finance a project with tax exempt bonds and could need to issue tax anticipation notes or may be considering a lease-purchase arrangement in the near future, we recommend implementing these policies as soon as possible. As a result, the Town would be able to answer “yes” to the questions on the Form 8038-G, thereby showing the IRS that it is aware of its post-issuance obligations under the Code and that it intends to meet those obligations. An additional reason for the timely adoption of these policies is the IRS’s indication that an issuer who discloses a compliance issue that is discovered as a result of its own internal review will be looked upon favorably by the IRS in determining a resolution to the problem.

RESOLUTION OF
THE SELECTBOARD
OF THE TOWN OF HANOVER, NEW HAMPSHIRE

June 2, 2025

WHEREAS, the Town of Hanover, New Hampshire (the “Town”) from time to time, on a tax-exempt basis, issues (i) bonds and bond anticipation notes to finance capital projects, (ii) tax anticipation notes to pay the Town’s maintenance and operation expenses and (iii) municipal leases to finance the lease-purchase of certain equipment, all pursuant to the provisions of New Hampshire RSA Chapter 33, as amended;

WHEREAS, the federal income tax laws included in the Internal Revenue Code of 1986, as amended (the “Code), require that issuers of tax-exempt debt comply with certain post-issuance requirements set forth in the Code;

WHEREAS, for purposes of maximizing the likelihood that the Town complies with such requirements of the Code, the Selectboard of the Town (the “Board”) desires to adopt the Post-Issuance Tax Compliance Policies and Procedures, attached hereto as Exhibit A;

NOW THEREFORE, BE IT RESOLVED by the Board as follows:

VOTED: That the Post-Issuance Tax Compliance Policies and Procedures, attached hereto as Exhibit A are hereby approved.

VOTED: That the Board hereby names the Director of Finance as the “Coordinator” under the Post-Issuance Tax Compliance Policies and Procedures and that the Director of Finance has accepted such nomination.

VOTED: That this resolution shall take effect from and after its adoption.

Carey Callaghan, Chair

Joanna Whitcomb, Vice Chair

Jarett Berke, Secretary

Jennie Chamberlain

Athos Rassias

EXHIBIT A

POST-ISSUANCE TAX COMPLIANCE POLICIES AND PROCEDURES

TOWN OF HANOVER, NEW HAMPSHIRE

POST-ISSUANCE TAX COMPLIANCE POLICY AND PROCEDURES FOR TAX-EXEMPT OBLIGATIONS

The purpose of this Post-Issuance Tax Compliance Policy and Procedures is to establish policies and procedures in connection with tax-exempt bonds and notes (the “Bond” or “Bonds”) issued by the Town of Hanover, New Hampshire (the “Issuer”) so as to maximize the likelihood that all applicable post-issuance requirements of federal income tax law needed to preserve the tax-exempt status of the Bonds are met.

1. Compliance Coordinator:

- a) The Director of Finance ("Coordinator") shall be responsible for monitoring post-issuance compliance.
- b) The Coordinator will maintain a copy of the transcript of proceedings in connection with the issuance of any tax-exempt obligations. The Coordinator will obtain such records as are necessary to meet the requirements of this policy.
- c) The Coordinator shall consult with bond counsel, a rebate consultant, financial advisor, Internal Revenue Service (“IRS”) publications and such other resources as are necessary to understand and meet the requirements of this policy.
- d) Training and education of the Coordinator and his/her staff will be sought and implemented upon the occurrence of new developments and upon the hiring of new personnel to implement this policy.

2. Record-Keeping.

a) Financing Transcripts. The Coordinator shall confirm the proper filing with the IRS of an 8038 Series return, and maintain a transcript of proceedings for all tax-exempt obligations issued by the Issuer, including but not limited to all tax-exempt bonds, notes and lease-purchase contracts. Each transcript shall be maintained for as long as the Bonds are outstanding, plus three (3) years after the final redemption date of the Bonds. Said transcript may be maintained in electronic format and shall include, at a minimum:

- 1) Form 8038s;
- 2) minutes, resolutions, and certificates;
- 3) certifications of issue price from the underwriter, if applicable;
- 4) formal elections required by the IRS;

- 5) trustee statements, if applicable;
- 6) records of refunded bonds, if applicable;
- 7) correspondence relating to bond financings;
- 8) reports of any IRS examinations for bond financings;
- 9) documents related to governmental grants associated with construction, renovation or purchase of bond financed facilities, if applicable; and
- 10) publications, brochures, and newspaper articles, where applicable.

b) Modification to Financing Documents. The Coordinator shall determine if there is any “significant modification” to bond documents resulting in reissuance under Treasury Regulations §1.1001-3, in consultation with bond counsel and any other legal counsel and financial advisor. The Coordinator shall retain proof of filing new Form 8038 and relevant documentation plus final rebate calculation on pre-modification bonds.

3. Proper Use of Proceeds. The Coordinator shall review the resolution authorizing issuance for each tax-exempt obligation issued by the Issuer and shall:

- a) obtain a computation of the yield on such issue from the Issuer’s financial advisor;
- b) create a separate Project Fund (with as many sub-funds as shall be necessary to allocate proceeds among the projects being funded by the issue) and a separate Cost of Issuance Fund as necessary to allocate proceeds to Bond issuance costs into which the proceeds of the issue shall be deposited, as applicable;
- c) review all requisitions, draw schedules, draw requests, invoices and bills requesting payment from the Project Fund;
- d) determine whether payment from the Project Fund is appropriate, and if so, make payment from the Project Fund (and appropriate sub-fund if applicable);
- e) maintain records of the payment requests and corresponding records showing payment;
- f) maintain records showing the earnings on, and investment of, the Project Fund;
- g) ensure that all investments acquired with proceeds are purchased at fair market value;
- h) identify bond proceeds or applicable debt service allocations that must be invested with a yield-restriction and monitor the investments of any yield-

restricted funds to ensure that the yield on such investments does not exceed the yield to which such investments are restricted;

- i) maintain records related to any investment contracts, credit enhancement transactions, and the bidding of financial products related to the proceeds; and
- j) monitor and maintain records of the reimbursement of costs previously expended by the Issuer to ensure that such reimbursement occurs not more than 18 months after the later of (i) the dates of the expenditures or (ii) the date the project/asset was placed in service (but not more than 3 years after the original expenditures were paid) except with respect to those expenditures for which the Issuer obtained a certificate of licensed engineer/architect to the effect that (I) at least five (5) years was necessary to complete the construction of the part of the project for which such expenditures were required; and (II) such expenditures shall be reimbursed not more than five (5) years after the date that the original expenditures were paid.

4. Arbitrage/Rebate Compliance and Timely Expenditure of Proceeds. The Coordinator shall review the No Arbitrage and Tax Certificate (or equivalent) (the “Certificate”) for each tax-exempt obligation issued by the Issuer and the expenditure records provided in Section 2 of this policy, above, and shall ensure that the Issuer takes the following actions:

- a) monitor and ensure that proceeds of each such issue are spent within the temporary period set forth in the Certificate;
- b) if at the time of issuance, it appears that that the Bonds will qualify for the small issuer exception to the rebate requirement, the Coordinator will monitor the amount of subsequent tax-exempt obligations issued or proposed to be issued in the calendar year in which the Bonds closed to ensure that the Issuer does not exceed the \$5 million or \$15 million threshold, as applicable, in such calendar year;
- c) if at the time of issuance, based on reasonable expectations set forth in the Certificate, it appears likely that the issue will qualify for an exemption from the rebate requirement, the Issuer may defer taking any of the actions set forth in subsection (d) below. Not later than the time of completion of construction or acquisition of the project, and depletion of all funds from the Project Fund, the Issuer shall make a determination if the expenditure of the Bond proceeds qualified for an exemption from the rebate requirements based on spending within a 6 month, 18 month or 2 year period after issuance. If a rebate exemption is determined to be applicable, the Issuer shall prepare and keep in the permanent records of the issue a memorandum evidencing this conclusion together with records of expenditure to support such conclusion. If the transaction does not qualify

for rebate exemption, the Issuer shall initiate the steps set forth in (d) below;

- d) if at the time of issuance it appears likely that arbitrage rebate calculations will be required, or upon determination that calculations are required pursuant to (c) above, the Issuer shall:
- i. engage the services of expert advisors (each a “Rebate Service Provider”) to assist in the calculation of arbitrage rebate payable in respect of the investment of Bond proceeds, or else shall ensure that it has adequate financial, accounting and legal resources of its own to make such calculations, and, prior to each rebate calculation date, cause the trustee or other financial institution investing bond proceeds to deliver periodic statements concerning the investment of Bond proceeds to the Rebate Service Provider;
 - ii. provide to the Rebate Service Provider additional documents and information reasonably requested by the Rebate Service Provider;
 - iii. monitor efforts of the Rebate Service Provider;
 - iv. assure payment of required rebate amounts, if any, no later than 60 days after each 5-year anniversary of the issue date of the Bonds, and no later than 60 days after the last Bond of each issue is redeemed;
 - v. during the construction period of each capital project financed in whole or in part by Bonds, monitor the investment and expenditure of Bond proceeds and consult with the Rebate Service Provider to determine compliance with any applicable exceptions from the arbitrage rebate requirements during each 6-month spending period up to 6 months, 18 months or 2 years, as applicable, following the issue date of the Bonds;
 - vi. retain copies of all arbitrage reports, trustee statements and other documents as required herein; and
 - vii. in lieu of engaging an outside Rebate Service Provider, the Issuer may make a determination that it has sufficient capabilities using its own personnel, supported by its regular accounting and legal advisers, to be able to make the required rebate calculations. Such determination shall be evidenced in writing with specific reference to the personnel and advisers to carry out the calculations, and such written determination shall be maintained in the records of the bond transaction.

5. Proper Use of Bond Financed Assets.

- a) The Coordinator shall maintain appropriate records and a list of all bond financed assets. Such records shall include the actual amount of proceeds (including investment earnings) spent on each of the bond financed assets.
- b) With respect to each bond financed asset, the Coordinator will monitor and confer with bond counsel with respect to all proposed:
 - i. management contracts,
 - ii. service agreements,
 - iii. research contracts,
 - iv. naming rights contracts,
 - v. leases or sub-leases,
 - vi. joint venture, limited liability or partnership arrangements,
 - vii. sale of property, or
 - viii. any other change in use of such asset.
- c) Section 141 of the Code sets forth private activity tests for the purpose of limiting the volume of tax-exempt bonds that finance activities of persons other than state and local governmental entities. These tests serve to identify arrangements that actually or reasonably expect to transfer the benefits of tax-exempt financing to non-governmental persons, including the federal government. The Coordinator shall provide to the users of any bond financed property a copy of this Compliance Policy and other appropriate written guidance advising that:
 - i. “Private business use” means use by any person other than the Issuer, including business corporations, partnerships, limited liability companies, associations, non-profit corporations, natural persons engaged in trade or business activity, and the United States of America and any federal agency, as a result of ownership of the property or use of the property under a lease, management or service contract (except for certain “qualified” management or service contracts), “naming rights” contract, “public-private partnership” arrangement, or any similar use arrangement that provides special legal entitlements for the use of the bond financed property;
 - ii. No more than 10% of the proceeds of any tax-exempt bond issue (including the property financed with the Bonds) may be used for private business use, of which no more than 5% of the proceeds of the tax-exempt bond issue (including the property financed with the bonds) may be used for any “unrelated” private business use – that is, generally, a private business use that is not functionally related to the government’s purposes of the Bonds; and no more than the lesser of \$5,000,000 or 5% of the proceeds of a tax-exempt bond issue may be used to make or finance a loan to any person

other than a state or local government unit;

- iii. Before entering into any special use arrangement with a non-governmental person that involves the use of bond financed property, the Coordinator will consult with bond counsel, provide bond counsel with a description of the proposed non-governmental use arrangement, and determine whether that use arrangement, if put into effect, will be consistent with the restrictions on private business use of the bond financed property; and
- iv. In connection with the evaluation of any proposed non-governmental use arrangement, the Issuer will consult with bond counsel to obtain federal tax advice in whether that use arrangement, if put into effect, will be consistent with the restrictions on private business use of the bond financed property, and, if not, whether any “remedial action” permitted under §141 of the Code may be taken as means of enabling that use arrangement to be put into effect without adversely affecting the tax-exempt status of the Bonds.
- d) The Coordinator shall maintain a copy of any such proposed agreement, contract, lease or arrangement, together with the response by bond counsel with respect to said proposal for at least three (3) years after retirement of all tax-exempt obligations issued to fund all or any portion of bond financed assets;
- e) The Coordinator shall consult with bond counsel and other legal counsel and advisers in the review of any change in use of bond-financed or refinanced assets to ensure compliance with all covenants and restrictions set forth in the Certificate;
- f) The Coordinator shall confer at least annually with other personnel responsible for bond-financed or refinanced assets to identify and discuss any existing or planned use of bond-financed or refinanced assets, to ensure that those uses are consistent with all covenants and restrictions set forth in the Certificate; and
- g) To the extent that the Coordinator discovers that any applicable tax restrictions regarding use of bond proceeds and bond-financed or refinanced assets will or may be violated, the Coordinator shall consult promptly with bond counsel and other legal counsel and advisers to determine a course of action to remediate all nonqualified bonds, if such counsel advises that a remedial action is necessary.

6. Bank Qualification. If the Bonds are issued in a par amount of \$10 million or less and designated by the Issuer as “bank qualified” under Section 265(b)(3) of the Code, the Coordinator will monitor the amount of subsequent tax-exempt

obligations issued or proposed to be issued in the calendar year in which the Bonds closed to ensure that the Issuer does not exceed the \$10 million threshold in such calendar year.

7. General Project Records. For each project financed with tax-exempt obligations, the Coordinator shall maintain a copy of all material documents relating to capital expenditures financed or re-financed by tax-exempt proceeds, until three (3) years after retirement of the tax-exempt obligations or obligations issued to refund those obligations including (without limitation), the following:

- a) appraisals, demand surveys or feasibility studies,
- b) applications, approvals and other documentation of grants,
- c) depreciation schedules,
- d) contracts respecting the project, including construction contracts,
- e) purchase orders,
- f) invoices,
- g) trustee requisitions and payment records,
- h) documents relating to costs reimbursed with Bond proceeds, and
- i) records identifying the assets or portion of assets that are financed or refinanced with Bond proceeds, including a final allocation of proceeds.

8. Advance Refundings. The Coordinator, shall be responsible for the following current, post issuance and record retention procedures with respect to advance refunding bonds:

- a) Identify and select bonds to be advance refunded with advice from internal financial personnel, and a financial advisor;
- b) The Coordinator shall identify, with advice from the financial advisor and bond counsel, any possible federal tax compliance issues prior to structuring any advance refunding;
- c) The Coordinator shall review the structure with the input of the financial advisor and bond counsel, of advance refunding issues prior to the issuance to ensure (i) that the proposed refunding is permitted pursuant to applicable federal tax requirements if there has been a prior refunding of the original bond issue; (ii) that the proposed issuance complies with federal income tax requirements which might impose restrictions on the redemption date of the refunded bonds; (iii) that the proposed issuance complies with federal income tax requirements which allow for the proceeds and replacement proceeds of an issue to be invested temporarily in higher yielding investments without causing the advance refunding bonds to become “arbitrage bonds”; (iv) that the proposed issuance will not result in the issuer’s exploitation of the difference between tax exempt and taxable interest rates to obtain a financial advantage nor overburden the tax exempt market in a way that might be considered an abusive

transaction for federal tax purposes; and (v) that the proposed refunding complies with applicable State law.

- d) The Coordinator shall collect and review data related to arbitrage yield restriction and rebate requirements for advance refunding bonds. To ensure such compliance, the Coordinator shall engage a rebate consultant to prepare a verification report in connection with the advance refunding issuance. Said report shall ensure said requirements are satisfied.
- e) The Coordinator shall, whenever possible, purchase SLGS to size each advance refunding escrow. The financial advisor and/or bond counsel shall be included in the process of subscribing SLGS. To the extent SLGS are not available for purchase, the Coordinator shall, in consultation with bond counsel and the financial advisor, comply with IRS regulations.
- f) To the extent the Issuer elects to purchase a guaranteed investment contract, the Coordinator shall ensure, after input from bond counsel, compliance with any bidding requirements set forth by the IRS regulations.
- g) In determining the issue price for any advance refunding issuance, the Coordinator shall obtain and retain issue price certification by the purchasing underwriter at closing.
- h) After the issuance of an advance refunding issue, the Coordinator shall ensure timely identification of violations of any federal tax requirements and engage bond counsel in attempt to remediate same in accordance with IRS regulations.

9. Continuing Disclosure. The Coordinator shall assure compliance with each continuing disclosure certificate and annually, per continuing disclosure agreements, file audited annual financial statements and other information required by each continuing disclosure agreement. The Coordinator will monitor material events as described in each continuing disclosure agreement and assure compliance with material event disclosure. Events to be reported shall be reported promptly, but in no event not later than ten (10) Business Days after the day of the occurrence of the event. Currently, such notice shall be given in the event of:

- a) Principal and interest payment delinquencies;
- b) Non-payment related defaults, if material;
- c) Unscheduled draws on debt service reserves reflecting financial difficulties;

- d) Unscheduled draws on credit enhancements relating to the bonds reflecting financial difficulties;
- e) Substitution of credit or liquidity providers, or their failure to perform;
- f) Adverse tax opinions, the issuance by the Internal Revenue Service of proposed or final determinations of taxability, Notices of Proposed Issue (IRS Form 5701-TEB) or other material notices or determinations with respect to the tax-exempt status of the bonds, or material events affecting the tax-exempt status of the bonds;
- g) Modifications to rights of Holders of the Bonds, if material;
- h) Bond calls (excluding sinking fund mandatory redemptions), if material, and tender offers;
- i) Defeasances of the bonds;
- j) Release, substitution, or sale of property securing repayment of the bonds, if material;
- k) Rating changes on the bonds;
- l) Bankruptcy, insolvency, receivership or similar event of the Issuer;
- m) The consummation of a merger, consolidation, or acquisition involving the Issuer or the sale of all or substantially all of the assets of the Issuer, other than in the ordinary course of business, the entry into a definitive agreement to undertake such an action or the termination of a definitive agreement relating to any such actions, other than pursuant to its terms, if material;
- n) Appointment of a successor or additional trustee or the change of name of a trustee, if material;

- o) Incurrence of a financial obligation of the Obligated Person, if material, or agreement to covenants, events of default, remedies, priority rights, or other similar terms of a financial obligation of the Obligated Person, any of which affect security holders, if material*; and
- p) Default, event of acceleration, termination event, modification of terms, or other similar events under the terms of a financial obligation of the Obligated Person, any of which reflect financial difficulties*.

10. Compliance with Continuing Disclosure Filings Under S.E.C. Rule 15c2-12. Under S.E.C. Rule 15c2-12, the Issuer may be required to periodically provide financial documentation, reports, notice and updates of documents to EMMA, the Electronic Municipal Market Access website managed by the Municipal Securities Rulemaking Board. Compliance is required in accordance with the Issuer's Material Events Disclosure Certificate and/or Continuing Disclosure Certificate executed in connection with a bond or note issue.

11. Due Diligence and Remedial Actions. In all activities related to the Issuer's Bonds, the Coordinator and his/her staff will exercise due diligence to comply with the Code provisions governing tax-exempt obligations. The Issuer is aware of (a) the Voluntary Closing Agreement Program (known as "VCAP") operated by the IRS which allows issuers to voluntarily enter into a closing agreement in the event of certain non-compliance with Federal tax requirements and (b) the remedial actions available under Section 1.141-12 of the Income Tax Regulations for private use of bond financed property which was not expected at the time the Bonds were issued.

* For purposes of events (o) and (p), "financial obligation" shall mean (a) a debt obligation, (b) a derivative instrument entered into in connection with, or pledged as security or a source of payment for, an existing or planned debt obligation, or (c) a guarantee of (a) or (b); provided, however, that a "financial obligation" shall not include any municipal security for which a final official statement has been provided to the MSRB consistent with the Continuing Disclosure S.E.C. Rule 15c2-12. "Obligated Person" shall mean the Issuer or any person committed by contract or other arrangement to support payment of all, or part, of the obligations on municipal securities. This definition does not include providers of municipal bond insurance, letters of credit or other liquidity facilities.

12. Periodic Review. The Issuer will monitor compliance with the guidelines contained in this policy as well as any other covenants not specifically included herein and will review and update these guidelines at least annually and whenever necessary due to change in law or circumstances.



Parks & Recreation Department

TOWN OF HANOVER, NH

48 Lebanon Street

Hanover, NH 03755

(603) 643-5315

hprpreservations@hanovernh.org

LIGHT POLE BANNER REQUEST (11SEP23)

ORGANIZATION CONTACT INFORMATION

Organization Name: Friends of Dartmouth Cancer Center

Organization Address: One Medical Center Drive (HB7070), Lebanon, NH 03756

Contact Name: Bruce Bouchard

Contact Title: Prouty Operations Dir.

Contact Phone: (603) 646-5283

Contact Email:

Bruce.a.bouchard@dartmouth.edu

Display Dates

Start: 06/16/25

End Date: 07/14/25

Display of banners cannot exceed 30 days.

BANNER INFORMATION

Number of Banners: 10

Banner Locations: *Please refer to [downtown banner location map](#).*

1

2

3

4

5

6

7

8

9

10

Narrative on why your banners should be displayed.

September 25, 2023

Town of Hanover
Board of Selectmen
P.O. BOX 483
Hanover, NH 03755

The annual Prouty raises needed funds to support cancer research and patient supportive services at Dartmouth Cancer Center and has taken place in Hanover for the past 44-year. For many years we have hung Prouty Pennants and a Main Street Banner in Hanover and we'd like to submit are request to do so again for 2025. We have found that hanging the pennants and banner to be extremely helpful in generating awareness for our event. As a result, we would like to submit a request to reserve the following dates if at all possible:

Prouty Pennant: (10) Light poles from June 16th - July 14th.

We appreciate your consideration for this request and look forward to hearing from you when time permits.

Sincerely,

Bruce Bouchard

Bruce Bouchard
Prouty Operations Director
Office: (603) 646-5283
Bruce.a.bouchard@dartmouth.edu

OFFICE USE ONLY

Selectboard Approval: YES NO

Signature:

Date:

Notes:

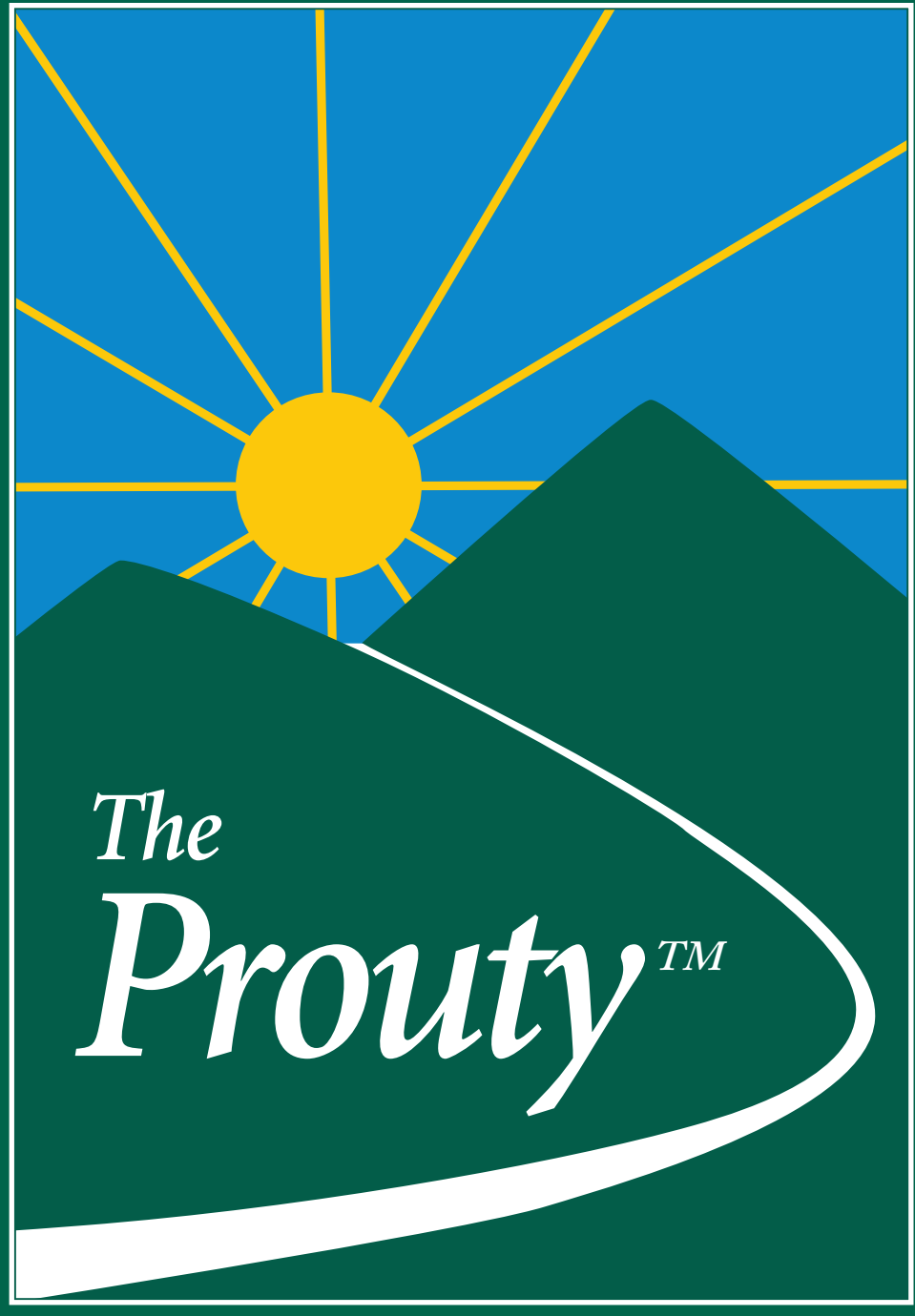

Benefiting:

Friends of
Dartmouth Cancer Center

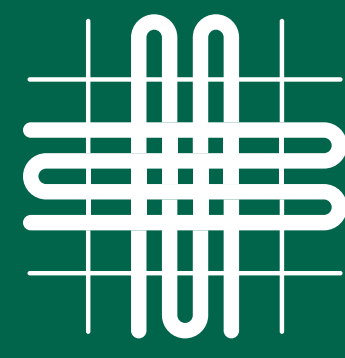

Dartmouth
Health



Dartmouth
GEISEL SCHOOL OF
MEDICINE

Go all in to end cancer.



Bike • Walk • Row • Golf
Ultimate • Virtual • Volunteer

Hanover, NH • July 8-9
TheProuty.org